

# CATALOGUE 2024

INNOVATIVE  
LED LIGHTING  
SOLUTIONS



**PLACEMONGER**  
LIGHTING

®

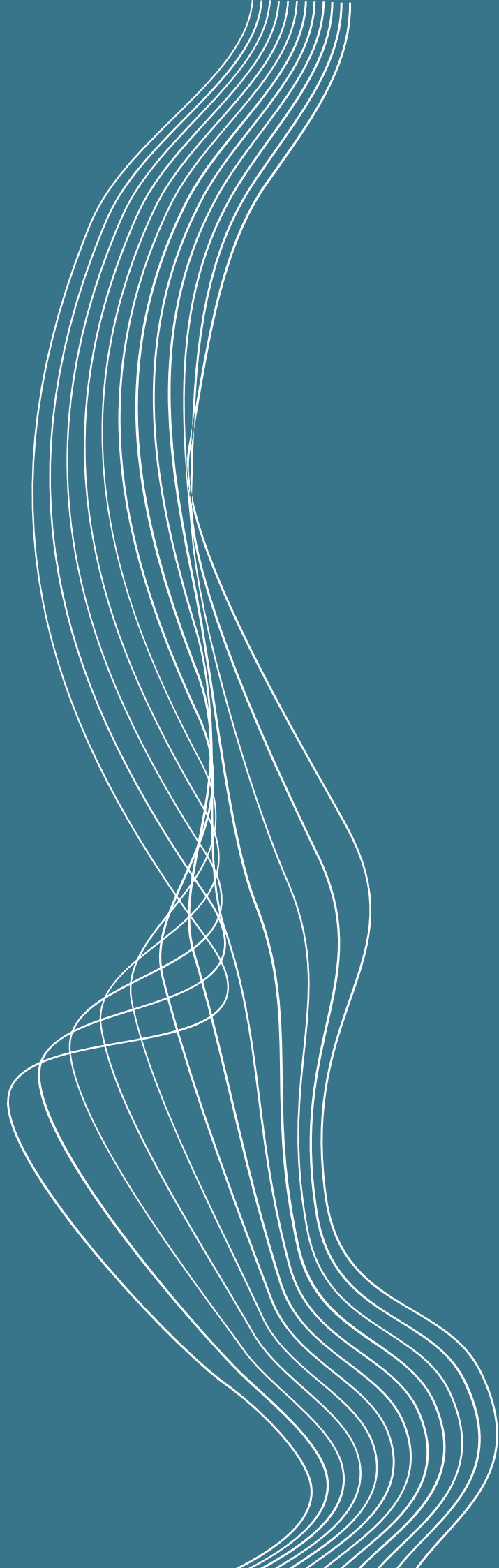



***Риасиотисиа***<sup>®</sup>  
**LIGHTING**

# INDEX

## GENERAL INDEX

IV	<i>Illustrated Index</i>
V - VI	<i>About Us</i>
VII	<i>Mission - Vision - Values</i>
VIII	<i>R&amp;D - Testing and Measures - Phaenomena Electronic Company</i>
IX	<i>Customer Support &amp; Lighting calculation - Patents - Certifications &amp; Partners</i>
X	<i>LED Technology - The phPOWER® technology - Optics</i>
XI	<i>Illuminating the Future: Phaenomena's presence worldwide</i>
XII	<i>Illuminating the Future: Gallery of Some of case study</i>
XIII	<i>How to read the catalogue</i>
XIV	<i>Legend of symbols</i>

### — STREET LIGHTING

02-03	phLUMINA <b>ELP2S</b>
04-05	phLUMINA <b>ELP2M</b>
06-07	phLUMINA <b>ELP</b>

### — RETROFIT

20-21	phLUMINA <b>EIP</b>
22-23	<b>Auriga</b>

### — FLOODLIGHTS

32-33	phEVO <b>GEMINI</b>
34-35	phEVO <b>STADIO</b>
36-37	phEVO <b>STADIOITA</b>

### — INDOOR | INDUSTRIAL

52-53	phLUMINA <b>OFFICE</b>
54-55	phEVO <b>INDUSTRIA</b>

### — URBAN ENVIRONMENT

11-12	phLUMINA <b>Trilogy</b> <small>TYPE-A</small>
13-14	phLUMINA <b>Trilogy</b> <small>TYPE-B</small>
15-16	phLUMINA <b>LQ</b>
17-18	phLUMINA <b>MARTE</b>

### — SOLAR POWERED LIGHT

26-27	ph <b>WOW</b>
28-29	phLUMINA <b>ELP2S_FV</b>

### — TUNNEL

40-41	phEVO <b>TUNNEL</b>
42-43	<b>Pegaso</b>
44-45	<b>CarLed</b>
46-47	<b>BladeWaterLed</b>
48-49	<b>ByPassLed</b>



# ILLUSTRATED INDEX

## STREET LIGHTING



phLUMINA**ELP2S**  
p. 02-03



phLUMINA**ELP2M**  
p. 04-05



phLUMINA**ELP**  
p. 06-07

## URBAN ENVIRONMENT



phLUMINA**Trilogy** Typ-A  
p. 10-11



phLUMINA**Trilogy** Typ-B  
p. 12-13



phLUMINA**LQ**  
p. 14-15



phLUMINA**MARTE**  
p. 16-17

## RETROFIT



phLUMINA**EIP**  
p. 20-21



**Auriga**  
p. 22-23

## SOLAR POWERED LIGHT



ph**WOW**  
p. 26-27



phLUMINA**ELP2S\_FV**  
p. 28-29

## FLOODLIGHTS



phEvo**GEMINI**  
p. 32-33



phEvo**STADIO**  
p. 34-35



phEvo**STADIOITA**  
p. 36-37

## TUNNEL

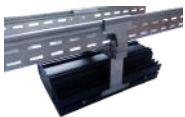

phEvo**TUNNEL**  
p. 40-41



**Pegaso**  
p. 42-43



**CarLed**  
p. 44-45

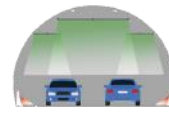

**BladeWaterLed**  
p. 46-47

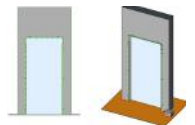

**ByPassLed**  
p. 48-49

## INDOOR | INDUSTRIAL



phLUMINA**OFFICE**  
p. 52-53



phEvo**INDUSTRIA**  
p. 54-55



Italian Innovations

**ILLUMINATES THE FUTURE**



# About Us

Welcome to Phaenomena Spa, where the art of lighting merges with exceptional Italian tradition. For almost two decades, we have been dedicated to creating tailor-made lighting devices, contributing to transforming the visibility of urban, recreational, sports, arterial road, tunnels, as well as industrial and commercial areas.

Sustainability and innovation are the driving principles of our business. At all our head quarter, we embrace green technology, producing clean and renewable energy through our rooftop solar panel installations. Furthermore, looking towards the future, we use eco-friendly materials such as aluminum, minimizing the use of resources like copper and plastic.

Our passion for lighting leads us to constantly collaborate with designers and industry experts from around the world, with whom we engage daily to welcome and develop the best ideas. This exchange allows us to offer cutting-edge solutions that not only enhance life in cities but transform it into unforgettable luminous experiences.

Each of our products is the result of excellent Italian craftsmanship, rooted in our history dating back to 2005. Thanks to our network of collaborators and national and international partnerships, we guarantee the highest quality and reliability in every detail.

Quality, reliability, and design are our fundamental pillars. We believe that aesthetics and functionality should harmoniously coexist, and each of our products embodies this philosophy. Every line, every curve has been conceived to blend elegance and innovation, creating a unique luminous experience.

However, our mission goes beyond simply creating lighting fixtures. Through our commitment to research and innovation, we aspire to contribute to a brighter and more sustainable world. We aim to make cities greener, safer, and more welcoming at night, promoting a culture of sustainable lighting among institutions, designers, and citizens.

At Phaenomena Spa, we do not limit ourselves to being a lighting company. We are a beacon of hope for a brighter and more sustainable future, guided by passion, innovation, research, and Italian excellence



# Mission

Our mission is to illuminate the world with passion, innovation, and Italian excellence, emphasizing the value of the "Made in Italy" brand and offering impeccable customer service.

We are committed to crafting bespoke lighting solutions that transform cities, towns, and all environments into brighter, livable, sustainable, and safe spaces, proudly upholding the tradition of Italian craftsmanship.

Collaborating with top professionals in the industry, we deliver superior-quality products that seamlessly blend aesthetics and functionality, while always maintaining a keen focus on detail and technological innovation.

Guided by ongoing research and a dedication to environmental stewardship, we aim to be a beacon of hope for a brighter and more sustainable future. We carry forward our country's heritage of craftsmanship and technology with pride, while also providing attentive and professional assistance that meets the needs of our customers.

# Vision

Our vision is to lead the lighting industry through innovation, sustainability, and excellence, projecting ourselves towards a bright and sustainable future.

We aim to continuously develop new technologies for both outdoor and indoor lighting, enhancing people's quality of life, safety, and environmental sustainability.

Technological innovation lies at the heart of our operations, while intelligent management of light resources is essential to maximize light effectiveness and reduce environmental impact. We are committed to using clean energy in all our activities, contributing to global energy conservation and the reduction of harmful emissions.

Looking ahead, we aspire to build a world where lighting plays a key role in creating safe and eco-friendly urban, residential, and industrial environments. With passion, dedication, and a keen eye for innovation, we inspire change and lead the way towards a bright and sustainable future, always upholding the quality and excellence of "Made in Italy."

# Values

- **Passion:** Our guiding force is the passion for lighting, innovation, and Italian excellence;
- **Innovation:** We continually pursue new technological and creative solutions to exceed our customers' expectations;
- **Excellence:** We commit ourselves unwaveringly to the quality of design, product functionality, quality, and customer support;
- **Sustainability:** We promote sustainable practices to reduce environmental impact and enhance the livability of cities, urban spaces, and streets;
- **Tradition:** We cherish and uphold the Italian artisanal heritage, a symbol of quality and attention to detail;

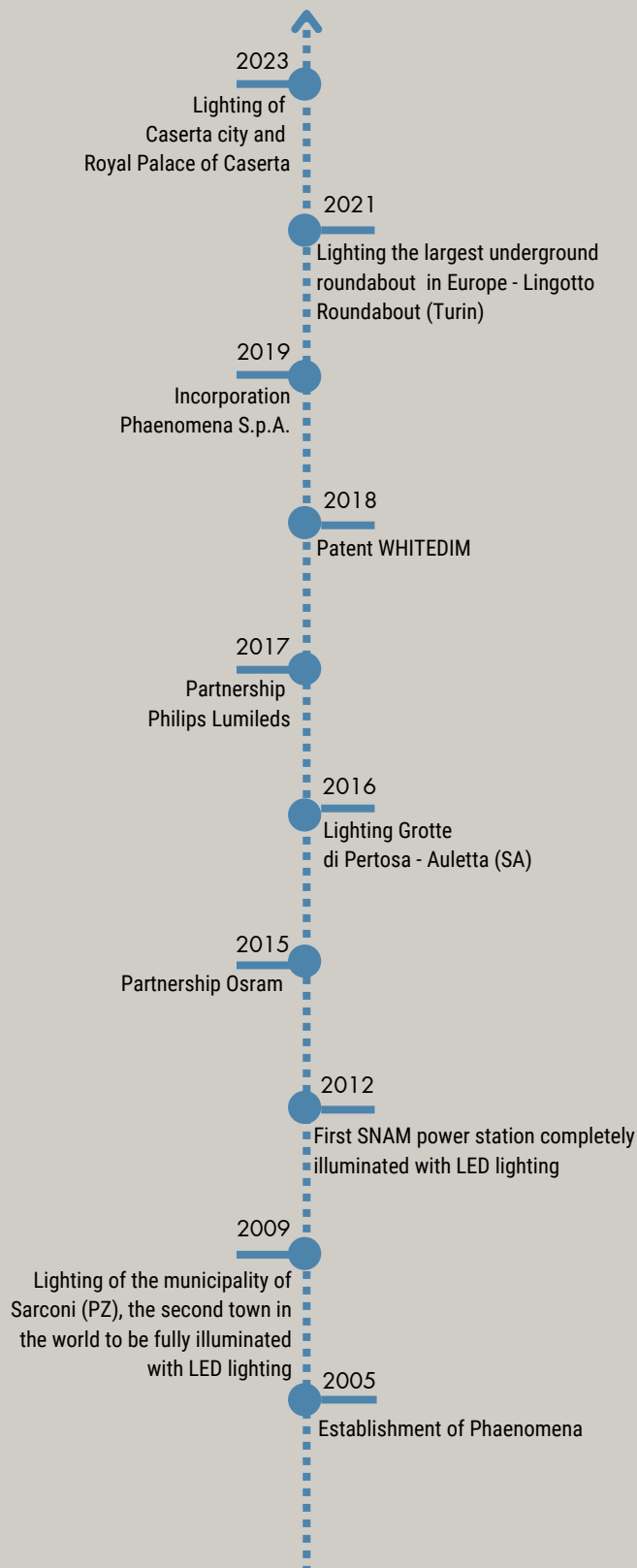

## R&D

In our operations, there is a deep commitment to research and development, a fundamental element managed internally within the company. At our technological center, we consistently invest in innovation to remain at the forefront of the lighting industry.

We actively collaborate with research institutions, universities, and global industry leaders to explore new frontiers in lighting science. Through a data-driven and experimental approach, we aim to develop increasingly efficient, sustainable, and cutting-edge lighting solutions.

Every product we bring to market is the result of thorough research and a rigorous development process aimed at meeting the emerging needs of our customers and addressing the challenges of the future.

Our passion for innovation and commitment to excellence guide us in pursuing the goal of creating a brighter and more sustainable world for all.

## Measurements and Testing

After the ideation and design of our products, at Phaenomena Spa, we are committed to ensuring the highest quality and safety through rigorous measurement and testing processes. Every product that leaves our production line undergoes a series of tests and preventive checks to verify compliance with industry standards and ensure optimal performance.

We have invested significantly in state-of-the-art machinery and equipment to build our laboratories with cutting-edge tools. This allows us to perform a wide range of tests, ranging from meticulous control of individual internal components to the evaluation of the structural resistance of our products.

At our photometric laboratory, we have advanced technologies that allow us to conduct detailed optical tests on lighting fixtures. These tests include measuring luminous intensity, light distribution, and color rendering, ensuring that our products offer optimal performance in terms of lighting and visual comfort.

Every stage of our measurement and testing process is designed to ensure the highest quality and reliability of our products, providing our customers with the assurance of investing in excellence of lighting solutions.

## Phaenomena Electronic Company

At Phaenomena Srl, the division specialized in electronics, we manage the entire electronic component of our products. Equipped with cutting-edge SMT (Surface Mount Technology) and THT (Through-Hole Technology) lines, our facility is furnished with innovative machinery and instrumentation to ensure maximum precision and quality. These include pick & place machines for SMT and THT, automatic screen printers, selective soldering machines, welding robots, and reflow ovens.

To ensure compliance and safety of our components, we employ integrating spheres with spectroradiometers and climatic chambers with multichannel data loggers to monitor temperatures. Additionally, we have CNC printers and 3D printers for rapid prototyping purposes.

For quality control of soldering, we utilize advanced technologies such as AOI (Automated Optical Inspection), X-ray machines, and mobile probe machines for the inspection and programming of electronic boards. With a steadfast commitment to innovation and precision, our laboratory is the beating heart of our production, ensuring the quality and reliability of our electronic products.

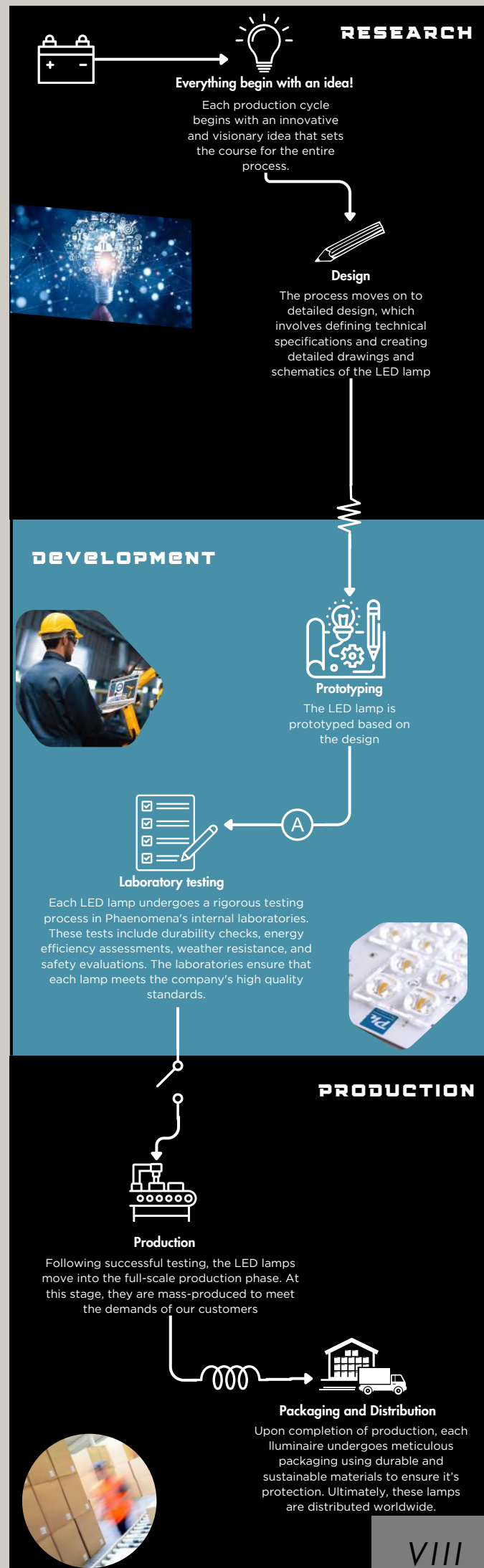



## Customer Support and Lighting calculations

At Phaenomena Spa, we are committed to providing comprehensive and professional customer support, both before and after sales. Our dedicated team is always ready to assist customers in every phase of the process:

Before purchase, our customer support team offers in-depth technical consultation and assistance in selecting the most suitable product for the specific needs of the customer. Additionally, Phaenomena provides its customers and designers with a lighting design assistance service. Through the use of advanced software, it is possible to consult the photometric characteristics of the fixture for appropriate application and develop detailed calculations on the level of illuminance and uniformity for every type of application.

After purchase, our commitment to customer satisfaction continues. We offer comprehensive post-sales support, ensuring that our customers are supported in case of questions, issues, or technical assistance needs. Our team is available to provide technical support, resolve any issues, and provide detailed instructions on installation, use, and maintenance of our products.

Furthermore, we offer warranty extension programs in addition to the basic warranty that covers our entire range of products.

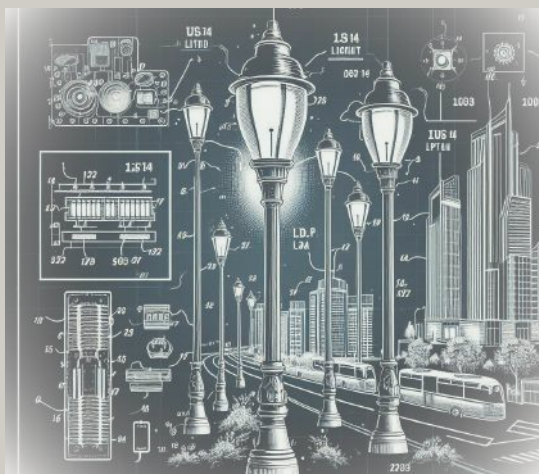
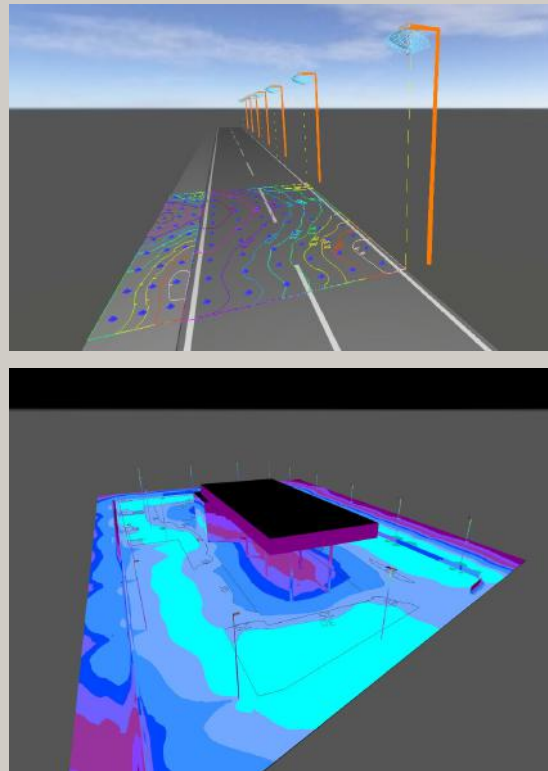

## Patents

- LED luminaire of the street type equipped with adaptive lighting photometry controllable remotely;
- LED lighting system that generates dynamic white light by actively varying the blue light component;
- Patent for industrial invention "Sistema di illuminazione delle gallerie stradali" (Road Tunnel Lighting System);
- Patent for industrial invention "Sistema di illuminazione di sicurezza" (Safety Lighting System);
- Patent for industrial invention "Alimentatore elettronico per apparecchi di illuminazione a LED" (Electronic Driver for LED Lighting Fixtures);
- Dual-channel power supply for the combined control of a pair of LED series generating dynamic white light.

## Certifications and Partnerships



EUROPEAN NORM ELECTRICAL CERTIFICATION



INTEGRATED ENVIRONMENTAL SUSTAINABILITY



## LED

### LED: What and how it works

The LED, acronym for Light Emitting Diode, are semiconductor devices that convert electrical energy directly into light through a process called electroluminescence. This occurs when electrons recombine with holes within the semiconductor material, releasing energy in the form of photons. The color of the emitted light depends on the type of semiconductor material used and its atomic structure. LEDs are known for their energy efficiency, long lifespan, and ability to produce variable-intensity light without the use of filaments or gases.

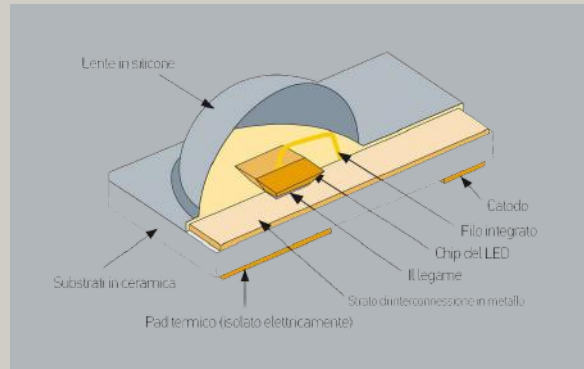

### LED: Life time

One of the main advantages of LEDs is their long lifespan. While traditional light bulbs may burn out in a few thousand hours, LEDs can last up to 100,000 hours or more, depending on various factors and usage conditions. This extended lifespan is due to the inherently robust nature of LEDs and their ability to maintain high levels of luminous efficiency over time. This results in lower maintenance and replacement costs in the long run, as well as a reduced environmental impact due to the decreased use of electrical energy.

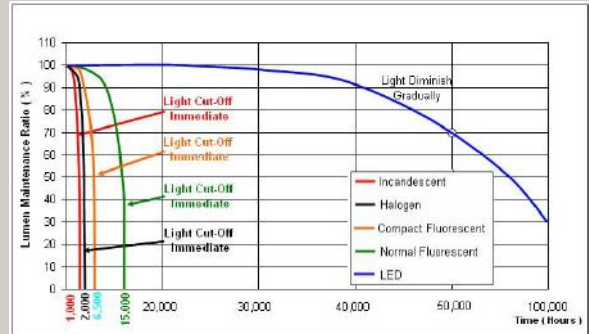

### LED: Light Quality

LEDs offer superior light quality compared to traditional light sources. Thanks to their precise controllability, LEDs allow for flexible adjustment of light intensity and color. This enables the creation of customized lighting environments to meet specific user needs, enhancing visual comfort and energy efficiency. Additionally, LEDs are capable of producing flicker-free light with superior color rendering, which renders colors more naturally and vividly.



## The phPOWER® technology

### The phPOWER® technology features:

#### WhiteDim®:

The Tunable White technology is capable of adjusting the color temperature to harmonize the artificial light produced by street lighting with daylight.

Temperature control is achieved through an algorithm that dynamically manages the LED power supply. Different color temperature management profiles can be set.

#### AUTODIM:

The AUTODIM mode allows for night-time power reduction based on an internal timer.

The power supply can automatically synchronize with the street lighting system's on/off times, significantly reducing costs. In this mode, power can be managed through adjusting the grid voltage.



## OPTICS

Optics made of PMMA, POLYCARBONATE, and SILICONE are optical components used in lighting to shape and direct light emitted by light sources, such as LEDs, in specific directions.

PMMA, acronym for polymethyl methacrylate, is also known as Plexiglas or acrylic glass. It is a transparent plastic material that offers good light transmission and greater impact resistance compared to glass. PMMA optics are lightweight, easy to work with, and suitable for applications where good light transmission with minimal dispersion is required.

POLYCARBONATE optics are optimized to harness the unique characteristics of LEDs. They offer numerous advantages, including higher luminous efficiency, impact resistance, heat resistance, and a wide range of design options for various lighting applications.

SILICONE is a flexible and weather-resistant material that allows the use of optics with complex shapes adaptable to various lighting design needs. Silicone optics offer excellent light transmission and can be used in challenging environmental conditions.

All these materials are used for the production of optics optimized for various lighting applications, such as street lighting, architectural lighting, and indoor and industrial lighting, as they can shape and direct light specifically, improving light distribution and reducing glare. The choice among the various optics depends on the specific project requirements and the environmental conditions in which they will be used.



## ILLUMINATING THE FUTURE: PHAENOMENA'S PRESENCE WORLDWIDE

Discover our installations, where with our cutting-edge products, we are transforming landscapes, streets, and cities worldwide. Already established in many countries across Europe and Middle East, our lighting solutions are leaving a luminous imprint in numerous locations.

Thanks to our commitment to innovation and sustainability, we are creating safer, more efficient, and aesthetically pleasing environments.

We continue to expand our reach to illuminate the future of cities worldwide





ILLUMINATING THE FUTURE: PHOTO GALLERY OF SOME OF OUR CASE STUDY

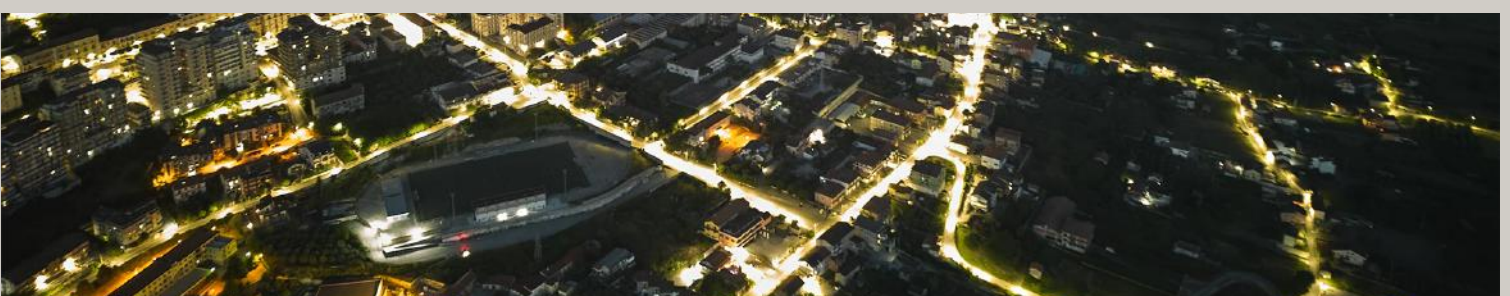
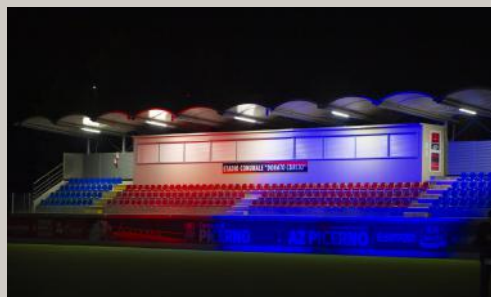
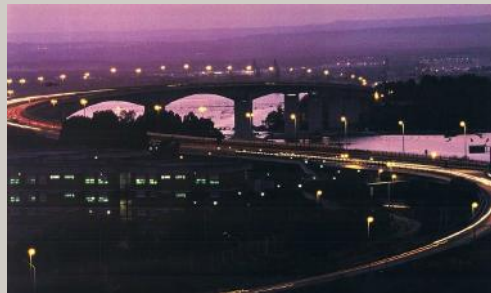



## HOW TO READ THE CATALOGUE

**phLUMINAELP2S** **1**

From the renowned lineage of Made in Italy comes the phLUMINAELP2S, distinguished not only for its illuminating capacity but also for its design.

The body of the lamp is made of die-cast aluminum, powder-coated. Its dimensions and shape are the result of careful design work aimed at ensuring the surface exposed to the wind, giving the product an elegant and robust line. The transparent tempered glass, resistant to impacts and thermal shocks, along with the LED components installed, complete a product characterized by high construction quality.

At the heart of the phLUMINAELP2S lies sophisticated technology. Thanks to the latest generation electronics and LED plate, ensuring an efficient and low brightness, contributing to reducing light pollution. Furthermore, its compatibility with DALI dimming allows it to adapt to modern lighting management needs.

With the phLUMINAELP2S, the excellence of Made in Italy joins practicality and technology to offer a state-of-the-art lighting solution, ideal for a wide range of urban and landscape scenarios. An ideal choice for illuminating streets, parking lots, and squares, this lampset ensures high visibility and creates a welcoming and soft atmosphere.

**KEY FEATURES**

- Power range: 8.5W to 35.0W
- Luminaire height: up to 120 mV
- LED Module
- Black City
- Photometric
- Detachable
- Customizable color temperature (K)

**2**

**3**

**4**

**5**

**MAIN CHARACTERISTICS**

Applications	Squares, Car parks, Parks and Squares, Pathways and Bike Paths, Railway Platforms, etc.
Material	High pressure die cast aluminum (EN-AL 6060)
Color	Anodized (optional DALI 7020). Epoxy powder coating after phosphating
Product size	515 (385x) x 228 x 117 (200) mm
Exposed surface	Area: 0.082 m <sup>2</sup> - 0.17 m <sup>2</sup>
Weight	4.5 kg
Mounting	Side entry / Post top Ø 80 mm
Tilt Angle	Bracket: 0° - 8° - 15° - 30° Post-top: 0° - 15° - 30°
Insulation Class	CL II (CL I on request)
Protection degree	IP 66   IK08 (IK09 on request)
No. LEDs	4 to 20 LEDs
LED Efficiency	201 lm/W - CRI > 70 - @ 300 mA, T = 25 °C   (CRI80 on request)
Color temperature	3000K - 3500K - 4000K - 4500K   5000K - 5700K   (Other DC available upon request)
LED Module	2 303.000W US016 LM 86, 16x21
Optics	PMMA convex optics in high-performance optical grade
Operating voltages and frequencies	220-240 V - 50/60 Hz
Power factor	Ca. 0.98 (at full load)
Surge protection (SPD)	8170 kV   SPD (up to 40 kV / 10 kA)   SPD (optional with higher capacity)
Control system (optional)	0-100% 0-10V signal, DALI, DALI, Astrodial, Marmot, Wireless, NEMA, ZIGBEE
Programming (optional)	On-site driver reprogramming through NFC and related app.
Dimming (optional)	Optional module for seasonal, weekly, and daily dimming.
Test:	Salt spray test environment (according to ASTM B 117-1997); Mechanical shock test (according to IEC 60068-2-27); Vibration test (according to IEC 60068-2-64); Humidity test (according to IEC 60068-2-78).
Operating temperature	-40 / +55 °C

**02** | STREET LIGHTING | phLUMINAELP2S **PHOSPHOR**

**6** **STREET LIGHTING**

**7**

**8**

**9**

**10**

**www.phospor.com** **phLUMINAELP2S | STREET LIGHTING | 03**

- 1** Article Name
- 2** Product Description
- 3** Key Features
- 4** Product Certifications
- 5** Main characteristics
- 6** Application example
- 7** QR Code to consult technical Datasheet
- 8** Link to consult technical Datasheet
- 9** Mechanical Characteristics
- 10** Product photos

## LEGEND OF SYMBOLS



Product compliant with safety requirements established by the European Community



Epoxy powder coatings: corrosion-resistant technology for advanced protection and durability



ENEC: Safety and conformity certification for electrical products



Additional thermal performance



ENEC PLUS: Safety and conformity certification with additional sustainability criteria



Indicates photobiological risks:

- RG 0 - EXEMPT RISK
- RG 1 - LOW RISK



IK code measures resistance to mechanical impact



Standards for Smart City intelligent streetlights



IP code indicates protection level against solids and liquids ingress



Restriction of Hazardous Substances



Class I insulation: supplementary protection, earth connection



Lead-free: products without lead presence.



Class II insulation, also known as double insulation, does not require earth connection.



LCA: Life Cycle Assessment of the product or process environmental impact throughout its life cycle



Class III: Protection against higher voltages absent, using very low safety extra-low voltage (SELV)



Product built in Italy, from design conception to production.



Salt spray test: Test of resistance to corrosion in aggressive environments



Product covered by basic warranty (up to 5 years or more) with possibility of extension (on request)







# STREET LIGHTING





# phLUMINAELP2S

From the renowned tradition of Made in Italy comes the phLuminaELP2S, distinguished not only for its illuminating capacity but also for its design.

The body is made of die-cast aluminum, powder-coated. Its dimensions and shape are the result of careful design work aimed at minimizing the surface exposed to the wind, giving the product an elegant and robust line. The transparent tempered glass, resistant to impacts and thermal shocks, along with the AISI 430 stainless steel bolts, complete a product characterized by high construction quality.

At the heart of the phLuminaELP2S lies cutting-edge technology, thanks to the latest generation electronics and LED plate, ensuring uniform and effective brightness, contributing to reducing light pollution. Furthermore, its compatibility with the smart city allows it to adapt to modern lighting management needs.

With the phLuminaELP2S, the excellence of Made in Italy joins practicality and technology to offer a state-of-the-art lighting solution, ideal for a wide range of urban and landscape contexts. An ideal choice for illuminating streets, parking lots, and squares, this lamppost ensures high visibility and creates a welcoming and safe atmosphere.

## KEY FEATURES

- Power range: 8.5W to 95.0W
- Luminous efficiency: Up to 159 lm/W
- LED lifetime >100,000 hours
- Smart City compatible
- Photocell options
- Optional dimming
- Customizable color temperature (k)



MAIN CHARACTERISTICS	
Applications	Roadways, Car parks, Parks and Squares, Pathways and Bike Paths, Railway Platforms, etc.
Material	High-pressure die cast aluminium UNI EN 46100
Color	Anthracite (optional RAL 7037). Epoxy powder coating after phosphating
Product sizes	595 (508) x 236 x 117 (202) mm
Exposed surface	Windage: 0.082 m <sup>2</sup> - 0.17 m <sup>2</sup>
Weight	6.0 Kg
Mounting	Side entry/ Post-top: Ø 60 mm
Tilt Angle	Bracket: 5°, 0°, -5°, -10°, -15°, -20° Post-top: 0°, +5°, +10°, +15°, +20°
Insulation Class	CL II   CL I (on request)
Protection degree	IP 66   IK08   IK09 (on request)
No. LEDs	4 to 24 LEDs
LED Efficacy	201 lm/W - CRI ≥ 70 - @ 360 mA, T = 25 °C   CRI≥80 (on request)
Color temperature	3000K - 730/669   4000K - 740/669   5700K - 757/669   Other (K) available upon request
LED lifetime	≥ 100.000hr L90B10 LM 80, TM-21
Optics	PMMA street optics in high-performance optical grade
Operating voltages and frequencies	220-240 V~ 50/60 Hz
Power factor	Cosφ ≥ 0.98 (at full load)
Surge protection (DM/CM)	6/10 kV   SPD (optional) 8kV / 10kV   SPD (optional) with higher capacity
Control system (options)	0-100%, 0-10V signal, PWM, DALI, AstroDIM, MainsDIM, Wireless, NEMA, ZHAGA
Programming (options)	On-site driver reprogramming through NFC and related app.
Dimming (options)	Optional module for seasonal, weekly, and daily dimming.
Test	Salt spray test environment (according to ASTM B 117-1997); Neutral salt spray(NSS) test(according to UNI ISO 9227); UV test (according to UV ISO 11507); Humidity test (according to UNI EN ISO 6270-1).
Operating temperature	-40 / +55 °C

# STREET LIGHTING

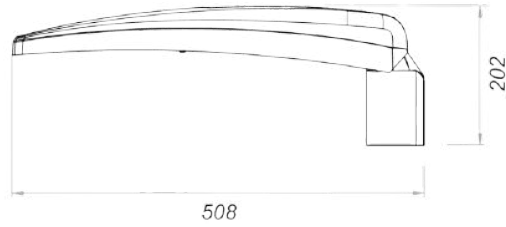
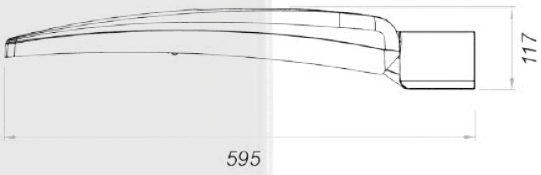

DATA SHEET

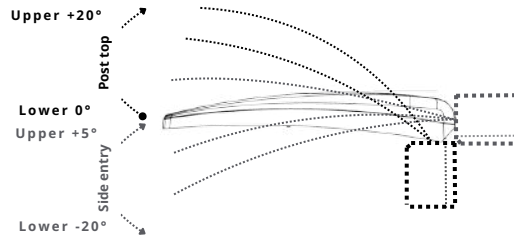
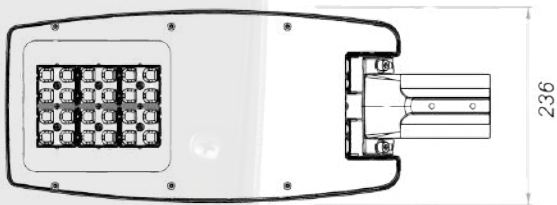

# phLUMINAELP2M

The phLuminaELP2M luminaire represents a precision-engineered solution designed to handle higher power outputs compared to its counterpart, the ELP2S model, making it the ideal option for illuminating larger areas. Characterized by a design developed and entirely manufactured in Italy, the phLuminaELP2M lamppost features a die-cast aluminum body that ensures exceptional durability over time.

Every detail of the product has been carefully selected: from the transparent tempered glass, resistant to impacts and thermal changes, to the AISI 430 stainless steel bolts. This attention to detail ensures product quality, while the use of cutting-edge technology in electronics and LED plate ensures uniform and effective brightness, minimizing light pollution.

Ideal for applications in wide streets, parking lots, squares, and other extensive spaces, the phLuminaELP2M luminaire seamlessly combines durability and sophistication, reflecting the excellence of Italian craftsmanship. We offer reliable, efficient, and durable lighting solutions to improve the safety and aesthetics of public spaces, with our phLuminaELP2M transforming every large outdoor environment into an icon of elegance and functionality.

## KEY FEATURES

- Power range: 8.5W to 120W
- Luminous efficiency: Up to 150 lm/W
- LED lifetime >100,000 hours
- Smart City compatible
- Photocell options
- Optional dimming
- Customizable color temperature (k)



MAIN CHARACTERISTICS	
Applications	Roadways, Car parks, Parks and Squares, Pathways and Bike Paths, Railway Platforms, etc.
Material	High-pressure die cast aluminium UNI EN 46100
Color	Anthracite (optional RAL 7037). Epoxy powder coating after phosphating
Product sizes	688 (603) X 279 X 117 (202) mm
Exposed surface	Windage: 0,082 m <sup>2</sup> - 0,17 m <sup>2</sup>
Weight	7.0 Kg
Mounting	Side entry/ Post-top: Ø 60 mm
Tilt Angle	Bracket: 5°, 0°, -5°, -10°, -15°, -20° Post-top: 0°, +5°, +10°, +15°, +20°
Insulation Class	CL II   CL I (on request)
Protection degree	IP 66   IK08
No. LEDs	4 to 36 LEDs
LED Efficacy	201 lm/W - CRI ≥ 70 - @ 360 mA, T = 25 °C   CRI ≥ 80 (on request)
Color temperature	3000K - 730/669   4000K - 740/669   5700K - 757/669   Other (K) available upon request
LED lifetime	≥ 100.000hr L90B10 LM 80, TM-21
Optics	PMMA street optics in high-performance optical grade
Operating voltages and frequencies	220-240 V~ 50/60 Hz
Power factor	Cosφ ≥ 0.98 (at full load)
Surge protection (DM/CM)	6/10 kV   SPD (optional) 8kV / 10kV   SPD (optional) with higher capacity
Control system (options)	0-100%, 0-10V signal, PWM, DALI, AstroDIM, MainsDIM, Wireless, NEMA, ZHAGA
Programming (options)	On-site driver reprogramming through NFC and related app.
Dimming (options)	Optional module for seasonal, weekly, and daily dimming.
Operating temperature	-40 / +55 °C



# STREET LIGHTING

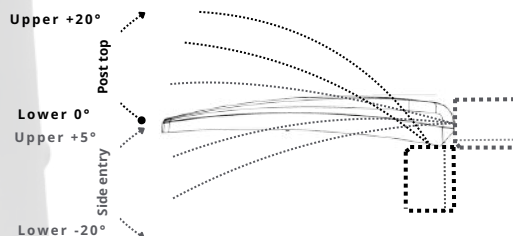
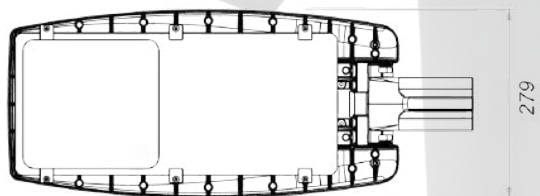
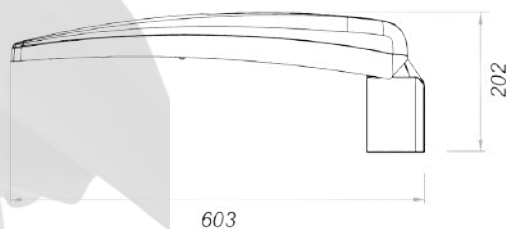

DATA SHEET



DATA SHEET



# phLUMINAELP

The phLuminaELP embodies our commitment to excellence, blending innovation and design in an extraordinary way. Its sleek silhouette, enriched by the carefully designed die-cast aluminum body, sets a new standard of durability and unmatched performance.

Equipped with an integrated inspection compartment that simplifies maintenance, tempered transparent glass resistant to impacts and thermal shocks, paired with AISI 304 stainless steel screws, this lamppost offers a perfect balance between robustness and attention to detail.

Thanks to the use of innovative technology, the phLuminaELP ensures effective and uniform brightness, contributing to reducing light pollution and improving environmental visibility.

Designed to illuminate wide streets, parking lots, squares, and other large spaces, this lamppost seamlessly blends longevity and sophistication, transforming every environment into a luminous and welcoming setting.

With the phLuminaELP, we offer a promise of reliability, efficiency, and charm, contributing significantly and durably to enhancing the safety and aesthetics of public spaces.

## KEY FEATURES

- Power range: 8W to 150W
- Luminous efficiency: Up to 148 lm/W
- LED lifetime >100,000 hours
- Smart City compatible
- Photocell options
- Optional dimming
- Customizable color temperature (k)



MAIN CHARACTERISTICS	
Applications	Roadways, Highways, Parking Lots, Parks and Plazas, Railway Platforms, etc.
Material	High-pressure die cast aluminium
Color	Gray RAL 7037. Epoxy powder coating whit anti-corrosion technology
Product sizes	620 (540) x 260 x 195 (260) mm - S version 690 (610) x 305 x 195 (260) mm - M version 920 (820) x 360 x 195 (260) mm - L version
Exposed surface	Windage: 0,086 m <sup>2</sup> - 0,140 m <sup>2</sup> Windage: 0,096 m <sup>2</sup> - 0,183 m <sup>2</sup> - M version Windage: 0,118 m <sup>2</sup> - 0,252 m <sup>2</sup> - L version
Weight	6.0 Kg - S version 7.0 Kg - M version 10.0 Kg - L version
Mounting	Side entry/ Post-top: Ø 60 mm
Tilt Angle	Bracket: 5°, 0°, -5°, -10°, -15°, -20° Post-top: 0°, +5°, +10°, +15°, +20°
Insulation Class	CL II   CL I (on request)
Protection degree	IP 66   IK08
No. LEDs	4 to 36 LEDs
LED Efficacy	201 lm/W - CRI ≥ 70 - @ 360 mA, T = 25 °C   CRI≥80 (on request)
Color temperature	3000K - 730/669   4000K - 740/669   5700K - 757/669   Other (K) available upon request
LED lifetime	≥ 100.000hr L90B10 LM 80, TM-21
Optics	PMMA street optics in high-performance optical grade
Operating voltages and frequencies	220-240 V~ 50/60 Hz
Power factor	Cosφ ≥ 0.98 (at full load)
Surge protection (DM/CM)	6/10 kV   SPD (optional) 8kV / 10kV   SPD (optional) with higher capacity
Control system (options)	0-100%, 0-10V signal, PWM, DALI, AstroDIM, MainsDIM, Wireless, NEMA, ZHAGA
Programming (options)	On-site driver reprogramming through NFC and related app.
Dimming (options)	Optional module for seasonal, weekly, and daily dimming.
Operating temperature	-40 / +55 °C



# STREET LIGHTING

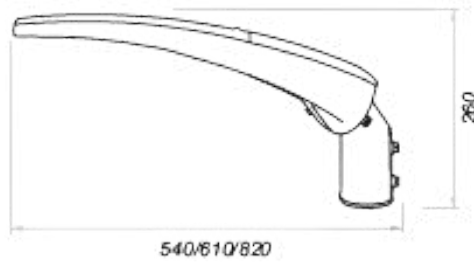
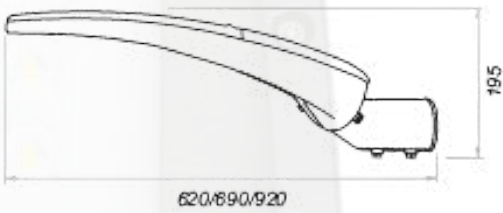

DATA SHEET



DATA SHEET

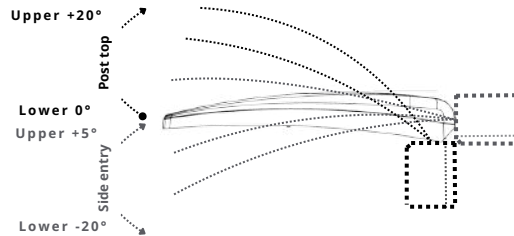
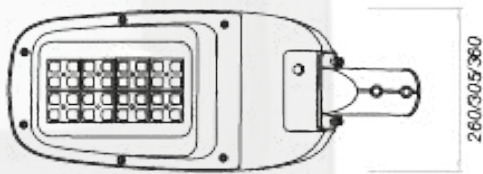







# URBAN ENVIRONMENT



# phLUMINA Trilogy Tipo-A

The phLuminaTrilogy line represents a product designed for urban environments, but its use extends far beyond, thanks to its versatility allowing integration in a wide range of contexts. Characterized by a minimalist style, this luminaire stands out for its elegant profile enriched with rounded corners, giving a distinctive touch to every environment.

The phLuminaTrilogy easily adapts to different settings due to its flexibility in terms of power and the multiple mounting options available. It can seamlessly integrate into varied settings, ranging from residential neighborhoods to historic centers, from parks to gardens, from squares to pedestrian streets, and much more.

In addition to being an icon of elegance, the phLuminaTrilogy is a tribute to Italian craftsmanship, with a process that enhances quality and tradition, from the design phase to the final realization. Its durability places it at the forefront of the industry, offering a range of intelligent management options that allow adaptability to continuously evolving needs.

## KEY FEATURES

- Power range: 12W to 76W
- Luminous efficiency: Up to 174.4 lm/W
- LED lifetime >100,000 hours
- Smart City compatible
- Photocell options
- Optional dimming
- Customizable color temperature (k)



MAIN CHARACTERISTICS	
Applications	Urban environments, Historic centers, Parks and Plazas, Sidewalks and Bike paths
Material	Aluminum / AISI 430 Steel / AISI 304 Steel.
Color	Anthracite. Epoxy powder coating with anti-corrosion technology.
Product sizes	Ø500 x 745 mm (Top Version) Ø500 x 200 mm ('S' Suspension Version) Ø500 x 235mm ('SF' Suspension Version) Ø500 x 340mm ('SZ' Suspension Version) Ø500 x 235mm ('SS' Suspension Version) 630 x 500 x 210mm (Bracket R1 Version) 675 x 500 x 295mm (Bracket R2 Version)
Exposed surface	Windage max: 0,196m <sup>2</sup> - entire range
Weight	from 6.0 Kg to 10.0 Kg
Mounting	Suspension, Top, Bracket
Tilt Angle	Bracket (R1-R2) da -10°, -5°, 0°, +5°, +10° (on request)
Insulation Class	CL II   CL I <i>on request</i>
Protection degree	IP 66   IK06
No. LEDs	8, 12, 16, 24, 36 LEDs
LED Efficacy	201 lm/W - CRI ≥ 70 - @ 360 mA, T = 25 °C   CRI≥80 on request
Color temperature	3000K - 730/669   4000K - 740/669   5700K - 757/669   Other (K) available upon request
LED lifetime	≥ 100.000hr L90B10 LM 80, TM-21
Optics	Optics in high-performance optical grade PMMA (IP Type) Optics in high-performance optical grade POLYCARBONATE (IP Type) Optics in high-performance optical grade SILICONE (IP Type)
Operating voltages and frequencies	220-240 V~ 50/60 Hz
Power factor	Cosφ ≥ 0.98 (at full load)
Surge protection (DM/CM)	6/10 kV   SPD (optional) 8kV / 10kV   SPD (optional) with higher capacity
Control system (options)	0-100%, 0-10V signal, PWM, DALI, AstroDIM, MainsDIM, Wireless, NEMA, ZHAGA
Programming (options)	On-site driver reprogramming through NFC and related app.
Dimming (options)	Optional module for seasonal, weekly, and daily dimming.
Operating temperature	-40 / +55 °C



# URBAN ENVIRONMENT

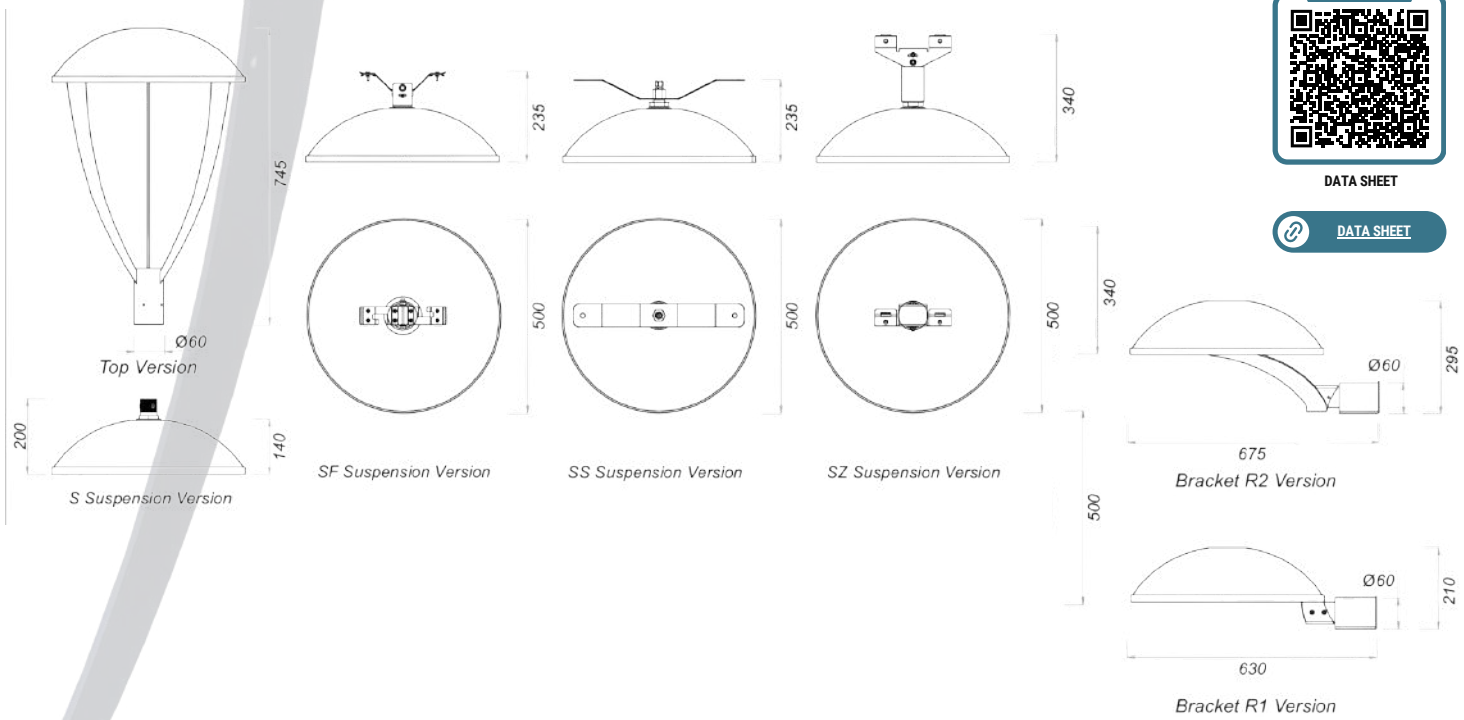

DATA SHEET



DATA SHEET



# phLUMINA Trilogy Tipo-B

The phLuminaTrilogy family is enriched with the addition of the Type-B variant, characterized by a slightly more rounded cap that gives the lamp a more imposing presence and greater power in terms of wattage. While maintaining all the distinctive features of its Type-A counterpart, this version stands out for its slightly larger dimensions and higher luminous capacity.

With its minimalist design, the phLuminaTrilogy Type-B seamlessly blends into a wide range of urban contexts and beyond, offering timeless elegance and unmistakable Italian craftsmanship. Whether it's residential neighborhoods, historic centers, parks, or pedestrian streets, this lamp integrates naturally, while also providing cutting-edge lighting performance and extraordinary durability.

Equipped with a wide range of management options, the phLuminaTrilogy Type-B is ready to meet the ever-evolving needs of our urban centers, representing a versatile and reliable solution for public lighting.

## KEY FEATURES

- Power range: 12W to 92W
- Luminous efficiency: Up to 174.4lm/W
- LED lifetime >100,000 hours
- Smart City compatible
- Photocell options
- Optional dimming
- Customizable color temperature (k)



MAIN CHARACTERISTICS	
Applications	Urban environments, Historic centers, Parks and Plazas, Sidewalks and Bike paths
Material	Aluminum / AISI 430 Steel / AISI 304 Steel.
Color	Anthracite. Epoxy powder coating with anti-corrosion technology.
Product sizes	Ø500 x 765 mm (Top Version) Ø500 x 220 mm ('S' Suspension Version) Ø500 x 255mm ('SF' Suspension Version) Ø500 x 360mm (Versione 'SZ' a fune) Ø500 x 255 mm ('SZ' Suspension Version) 630 x 500 x 230 mm (Bracket R1 Version) 675 x 500 x 315 mm (Bracket R2 Version)
Exposed surface	Windage max: 0,196m <sup>2</sup> - entire range
Weight	da 6.0 Kg a 10.0 Kg
Mounting	Suspension, Top, Bracket
Tilt Angle	Bracket (R1-R2) da -10°, -5°, 0°, +5°, +10° (on request)
Insulation Class	CL II   CL I <i>on request</i>
Protection degree	IP 66   IK06
No. LEDs	8, 12, 16, 24, 36 LEDs
LED Efficacy	201 lm/W - CRI ≥ 70 - @ 360 mA, T = 25 °C   CRI≥80 on request
Color temperature	3000K - 730/669   4000K - 740/669   5700K - 757/669   Altre (K) disponibili su richiesta
LED lifetime	≥ 100.000hr L90B10 LM 80, TM-21
Optics	Optics in high-performance optical grade PMMA (IP Type) Optics in high-performance optical grade POLYCARBONATE (IP Type) Optics in high-performance optical grade SILICONE (IP Type)
Operating voltages and frequencies	220-240 V~ 50/60 Hz
Power factor	Cosφ ≥ 0.98 (at full load)
Surge protection (DM/CM)	6/10 kV   SPD (optional) 8kV / 10kV   SPD (optional) with higher capacity
Control system (options)	0-100%, 0-10V signal, PWM, DALI, AstroDIM, MainsDIM, Wireless, NEMA, ZHAGA
Programming (options)	On-site driver reprogramming through NFC and related app.
Dimming (options)	Optional module for seasonal, weekly, and daily dimming.
Operating temperature	-40 / +55 °C



# URBAN ENVIRONMENT

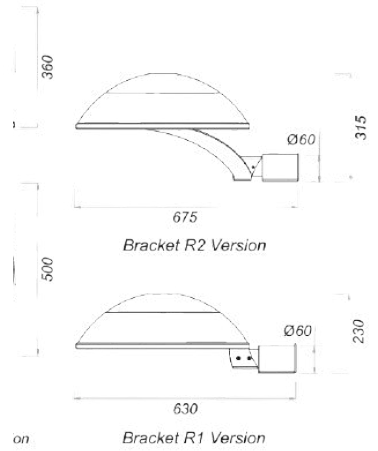
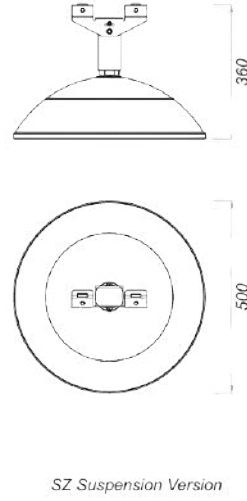
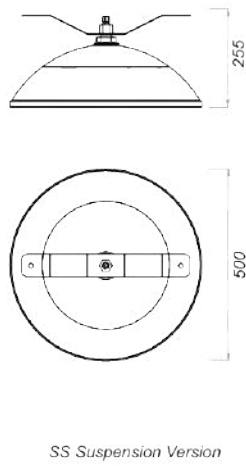
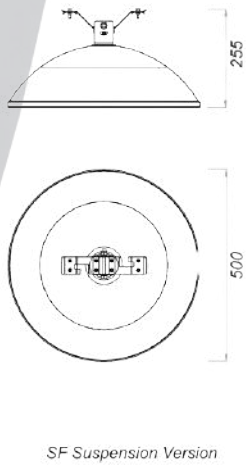
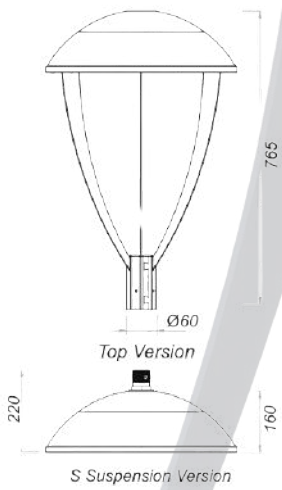

DATA SHEET



DATA SHEET



# phLUMINALQ

The phLuminalQ, a lantern that embodies the essence of classic elegance and timeless design, conceived with particular attention to urban environments and a deep respect for tradition.

Characterized by its square lines and traditional aesthetic, the phLuminalQ adds a touch of nostalgia to contemporary spaces, thanks to its meticulous attention to detail. This lantern seamlessly integrates into historic centers, residential neighborhoods, parks, gardens, squares, and pedestrian streets, imparting a refined elegance to every setting.

Every detail, from the initial design phase to the final construction, reflects an unequivocal commitment to unparalleled quality.

At the forefront of innovation and longevity, the phLuminalQ harmoniously blends classic elegance with modern intelligence. Its range of management options ensures adaptability to the changing needs of urban life, providing a versatile and reliable lighting solution.

## KEY FEATURES

- Power range: 12W to 76W
- Luminous efficiency: Up to 174.4lm/W
- LED lifetime >100,000 hours
- Smart City compatible
- Photocell options
- Optional dimming
- Customizable color temperature (k)



MAIN CHARACTERISTICS	
Applications	Urban environments, Historic centers, Parks and Plazas, Sidewalks and Bike paths, etc
Material	High-pressure die cast aluminium UNI EN 46100
Color	RAL 9005 embossed. Epoxy powder coating with anti-corrosion technology.
Product sizes	450 x 760 mm (Top Version) 450 x 800 mm (Suspension)
Exposed surface	Windage max: 0,202m <sup>2</sup> - entire range
Weight	9.0 Kg
Mounting	Suspension, Top
Insulation Class	CL II   CL I <i>on request</i>
Protection degree	IP 66   IK06
No. LEDs	8, 12, 16, 24, 36 LEDs
LED Efficacy	201 lm/W - CRI ≥ 70 - @ 360 mA, T = 25 °C   CRI≥80 on request
Color temperature	3000K - 730/669   4000K - 740/669   5700K - 757/669   Altre (K) disponibili su richiesta
LED lifetime	≥ 100.000hr L90B10 LM 80, TM-21
Optics	Optics in high-performance optical grade PMMA (IP Type) Optics in high-performance optical grade POLYCARBONATE (IP Type) Optics in high-performance optical grade SILICONE (IP Type)
Operating voltages and frequencies	220-240 V~ 50/60 Hz
Power factor	Cosφ ≥ 0.98 (at full load)
Surge protection (DM/CM)	6/10 kV   SPD (optional) 8kV / 10kV   SPD (optional) with higher capacity
Control system (options)	0-100%, 0-10V signal, PWM, DALI, AstroDIM, MainsDIM, Wireless, NEMA, ZHAGA
Programming (options)	On-site driver reprogramming through NFC and related app.
Dimming (options)	Optional module for seasonal, weekly, and daily dimming.
Operating temperature	-40 / +55 °C

# URBAN ENVIRONMENT

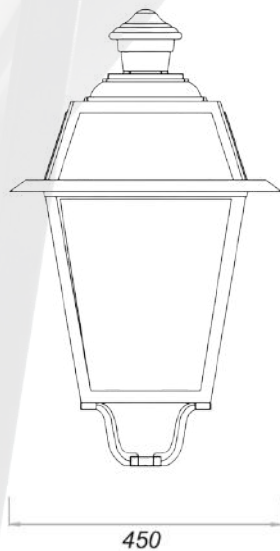

TOP Version

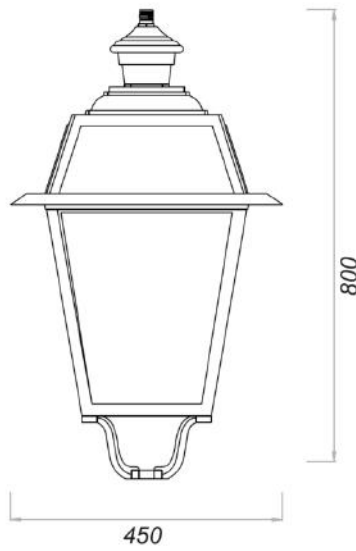

S Version (suspension)



DATA SHEET



DATA SHEET





# phLUMINAMARTE

The phLuminaMarte has been designed to meet the most sophisticated needs of urban environments. With a sophisticated aesthetic that exudes refinement and modernity, this lighting solution stands out for its impeccable design and attention to detail.

Its elegant lines give phLuminaMarte an unparalleled prestige, conveying exclusivity and sophistication. Thanks to its versatility, phLuminaMarte elegantly fits into a wide range of urban contexts, from residential areas to historic centers, from parks to gardens, from squares to pedestrian streets, and beyond.

In addition to providing quality lighting, phLuminaMarte is an expression of high-level craftsmanship, highlighting the excellence of Italian craftsmanship. Every detail, from the initial design phase to the final construction, reflects a commitment to ensuring uncompromising quality.

Thanks to its longevity and innovation, phLuminaMarte stands at the forefront of the industry. In addition to embodying elegance, it introduces technology with a range of management options that ensure maximum adaptability to the changing needs of urban life.

Immerse yourself in the world of quality lighting with phLuminaMarte, where style, craftsmanship, and innovation converge in perfect harmony to create a unique and unparalleled lighting experience.

## KEY FEATURES

- Power range: 12W to 76W
- Luminous efficiency: Up to 174.4lm/W
- LED lifetime >100,000 hours
- Smart City compatible
- Photocell options
- Optional dimming
- Customizable color temperature (k)



MAIN CHARACTERISTICS	
Applications	Urban environments, Historic centers, Parks and Plazas, Sidewalks and Bike paths, etc
Material	High-pressure die cast aluminium UNI EN 46100
Color	Anthracite. Epoxy powder coating with anti-corrosion technology.
Product sizes	Ø485 x 650 mm (Top Version) Ø485 x 165 mm ('S' suspension Version) Ø485 x 330 mm ('SZ' Version) 552 x 485 x 238 mm (Top R1 Version) 661 x 485 x 129 mm (Bracket R1 Version)
Exposed surface	Windage: 0,18 m <sup>2</sup> - 0,062 m <sup>2</sup> - Version S - R1 - SZ Windage: 0,18 m <sup>2</sup> - 0,085 m <sup>2</sup> - Version post-top
Weight	7.0 Kg
Mounting	Bracket or Top R1 (pole Ø60/80) Top (palo Ø60)
Tilt angle	R1 version from 20°, -15°, -10°, -5°, 0°, 5°, 10°, 15°, 20° (on request)
Insulation Class	CL II   CL I <i>on request</i>
Protection degree	IP 66   IK06
No. LEDs	8, 12, 16, 24, 36 LEDs
LED Efficacy	201 lm/W - CRI ≥ 70 - @ 360 mA, T = 25 °C   CRI≥80 on request
Color temperature	3000K - 730/669   4000K - 740/669   5700K - 757/669   Altre (K) disponibili su richiesta
LED lifetime	≥ 100.000hr L90B10 LM 80, TM-21
Optics	Optics in high-performance optical grade PMMA (IP Type) Optics in high-performance optical grade POLYCARBONATE (IP Type) Optics in high-performance optical grade SILICONE (IP Type)
Operating voltages and frequencies	220-240 V~ 50/60 Hz
Power factor	Cosφ ≥ 0.98 (at full load)
Surge protection (DM/CM)	6/10 kV   SPD (optional) 8kV / 10kV   SPD (optional) with higher capacity
Control system (options)	0-100%, 0-10V signal, PWM, DALI, AstroDIM, MainsDIM, Wireless, NEMA, ZHAGA
Programming (options)	On-site driver reprogramming through NFC and related app.
Dimming (options)	Optional module for seasonal, weekly, and daily dimming.
Operating temperature	-40 / +55 °C

# URBAN ENVIRONMENT

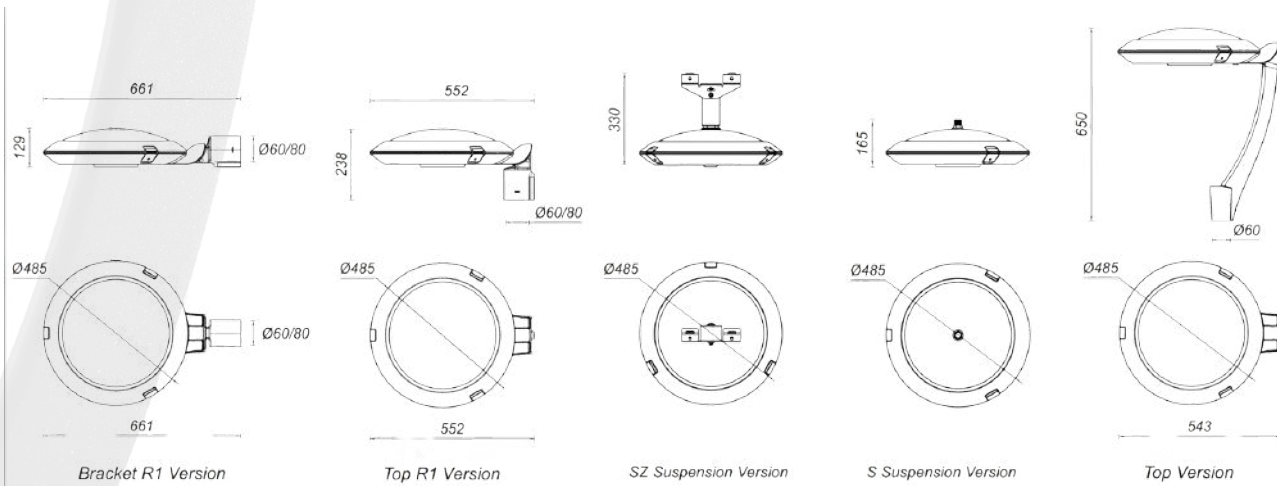

DATA SHEET







# RETROFIT



# phLUMINA EIP

The phLuminaEIP retrofit module represents an innovative lighting solution, specially designed for relamping older fixtures, with the aim of combining savings and efficiency while bringing new light. Thanks to its adaptability and versatility, this retrofit module is designed to be installed in various models of old luminaires, giving them a touch of refinement and modernity.

The tangible benefits of this module are manifold: the integration of cutting-edge LED technology allows for a significant reduction in energy consumption while ensuring uniform lighting. The ease and speed of installation make relamping with phLuminaEIP an easy, efficient, and hassle-free operation, eliminating the need to replace the entire fixture.

phLuminaEIP not only improves existing lighting but also underscores a commitment to environmental sustainability thanks to its extended energy efficiency. With an extended operating life, this retrofit module combines cutting-edge performance with quality materials, representing a durable and sustainable choice that breathes new life into old luminaires.

## KEY FEATURES

- Power range: 12W to 116W
- Luminous efficiency: Up to 174.4lm/W
- LED lifetime >100,000 hours
- Smart City compatible
- Photocell options
- Optional dimming
- Customizable color temperature (k)



MAIN CHARACTERISTICS	
Applications	Lamposts, luminaries
Material	D-Bond/Extruded aluminium
Color	On request
Product sizes	Customizable
Weight	< 5 kg
Mounting	Within existing luminaires
Insulation Class	CL II   CL I on request
Protection degree	IP 66   IK06
No. LEDs	8, 12, 16, 24, 36 LEDs
LED Efficacy	201 lm/W - CRI ≥ 70 - @ 360 mA, T = 25 °C   CRI≥80 on request
Color temperature	3000K - 730/669   4000K - 740/669   5700K - 757/669   Altre (K) disponibili su richiesta
LED lifetime	≥ 100.000hr L90B10 LM 80, TM-21
Optics	Optics in high-performance optical grade PMMA (IP Type) Optics in high-performance optical grade POLYCARBONATE (IP Type) Optics in high-performance optical grade SILICONE (IP Type)
Operating voltages and frequencies	220-240 V~ 50/60 Hz
Power factor	Cosφ ≥ 0.98 (at full load)
Surge protection (DM/CM)	6/10 kV   SPD (optional) 8kV / 10kV   SPD (optional) with higher capacity
Control system (options)	0-100%, 0-10V signal, PWM, DALI, AstroDIM, MainsDIM, Wireless, NEMA, ZHAGA
Programming (options)	On-site driver reprogramming through NFC and related app.
Dimming (options)	Optional module for seasonal, weekly, and daily dimming.
Operating temperature	-40 / +55 °C



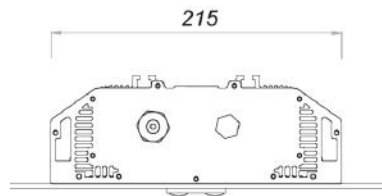
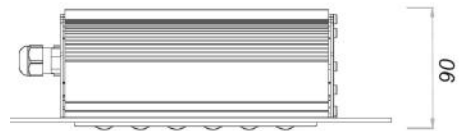
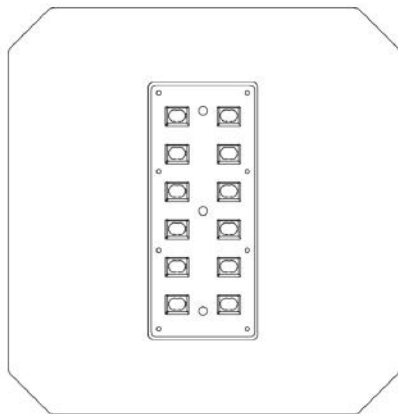

DATA SHEET



DATA SHEET



# Auriga

AURIGA is a cutting-edge retrofit lighting solution specially designed for relamping fixtures, with the aim of combining savings and efficiency while bringing new light. Designed to transform spaces with 360° enveloping light and a wider beam.

This innovative lighting module stands out for its ability to uniformly illuminate environments, diffusing distributed light that creates a welcoming and comfortable atmosphere. Its advanced technology allows for optimal light distribution, ensuring uniform and shadow-free illumination.

Thanks to its versatility and customization options, AURIGA easily adapts to a variety of environments, from residential areas to historic centers and outdoor spaces. Its simple and fast installation makes it ideal for retrofitting existing lighting systems, offering high-quality lighting and superior energy efficiency.

With AURIGA, transform your spaces into bright, cozy, and inviting places, creating an ideal environment to live and relax.

## KEY FEATURES

- Power range: 12W to 70W
- Luminous efficiency: Up to 128 lm/W
- LED lifetime >100,000 hours
- Smart City compatible
- Photocell options
- Optional dimming
- Customizable color temperature (k)



MAIN CHARACTERISTICS	
Applications	Lamposts, luminaries
Material	D-Bond   Extruded aluminium
Color	On request
Product sizes	Customizable
Weight	< 5 kg
Mounting	Within existing luminaires
Insulation Class	CL II   CL I <i>on request</i>
Protection degree	IP 66   IK06
No. LEDs	8, 12, 16, 24, 36 LEDs
LED Efficacy	201 lm/W - CRI ≥ 70 - @ 360 mA, T = 25 °C   CRI≥80 on request
Color temperature	3000K - 730/669   4000K - 740/669   5700K - 757/669   Altre (K) disponibili su richiesta
LED lifetime	≥ 100.000hr L90B10 LM 80, TM-21
Optics	Optics in high-performance optical grade PMMA (IP Type) Optics in high-performance optical grade POLYCARBONATE (IP Type) Optics in high-performance optical grade SILICONE (IP Type)
Operating voltages and frequencies	220-240 V~ 50/60 Hz
Power factor	Cosφ ≥ 0.98 (at full load)
Surge protection (DM/CM)	6/10 kV   SPD (optional) 8kV / 10kV   SPD (optional) with higher capacity
Control system (options)	0-100%, 0-10V signal, PWM, DALI, AstroDIM, MainsDIM, Wireless, NEMA, ZHAGA
Programming (options)	On-site driver reprogramming through NFC and related app.
Dimming (options)	Optional module for seasonal, weekly, and daily dimming.
Operating temperature	-40 / +55 °C



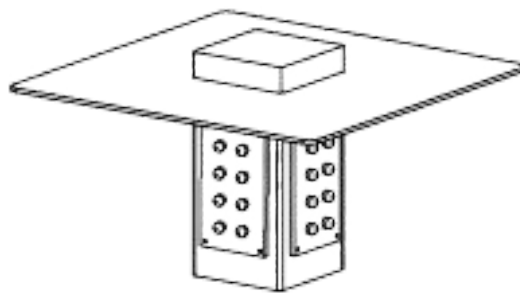
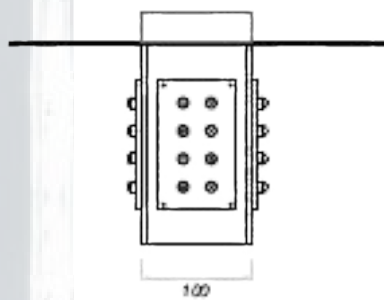

DATA SHEET









# SOLAR POWERED LIGHT





The phWOW is a lighting fixture that combines effectiveness, versatility, and sustainable technology. Powered by solar energy, this device not only illuminates spaces but also stands out as an icon of eco-friendly innovation.

The integrated photovoltaic panels in the structure capture solar energy, providing a clean and renewable power source. The phWOW luminaire offers significant benefits: it reduces dependence on conventional energy sources and minimizes environmental impact by harnessing green energy sources.

The intelligent energy management system ensures efficient distribution, optimizing the use of solar energy to ensure constant and reliable illumination throughout the night. Additionally, the phWOW is equipped with lithium batteries that provide up to 3 days of operation with 8 hours of daily lighting.

The brightness adjustment function and battery charging activation contribute to a balanced use of energy, offering a prolonged and efficient lighting solution.

## KEY FEATURES

- Power: 36W
- Efficacy up to 160 lm/W
- Battery capacity: 30Ah to 40Ah
- Solar panel power: 90W to 120W
- Lifetime LED: >100,000hr
- Dimming Options
- Colour Temperature Options
- Lithium Battery



MAIN CHARACTERISTICS	
Applications	Streets, parks, sidewalks, bike paths, green areas, etc.
Material	Stainless Steel 430
Color	RAL 7035 - Epoxy powder coating with anti-corrosion technology
Product sizes	1030 x 680 x 327 mm 780 x 680 x 324 mm
Exposed surface	Windage: 0.70 m <sup>2</sup> - 0.13 m <sup>2</sup> - 0.10 m <sup>2</sup> Windage: 0.53 m <sup>2</sup> - 0.13 m <sup>2</sup> - 0.08 m <sup>2</sup>
Weight	max 27Kg
Mounting	Post Top (Ø 89 mm)
Insulation Class	CL III (SELV)
Protection degree	IP 66   IK06
No. LEDs	12 LED
LED Efficacy	201 lm/W - CRI ≥ 70 - @ 360 mA, T = 25 °C   CRI≥80 on request
Color temperature	3000K - 730/669   4000K - 740/669   5700K - 757/669   Other (K) available upon request
LED lifetime	≥ 100.000hr L90B10 LM 80, TM-21
Optics	Optics in high-performance optical grade PMMA (IP Type) Optics in high-performance optical grade POLYCARBONATE (IP Type) Optics in high-performance optical grade SILICONE (IP Type)
Operating voltages	12 VDC
Solar Panel Power	from 90W to 120W
Battery Capacity	from 30 to 40Ah lithium
Autonomy	3 days fully charged Lithium Battery
Dimming	Dimming based on battery charge or preset times (programmable)
Charge Controller	MPPT with twilight function or preset times (programmable) Efficiency ≥ 94%
FON (function always on)	Integrated device with a function algorithm that takes into account the battery's charge status and adjusts the current output to ensure 8 hours of operation.
S/P Ratio (Scotopic/Photopic)	≥ 1,4
Operating temperature	-20° / +50 °C

# SOLAR POWERED LIGHT

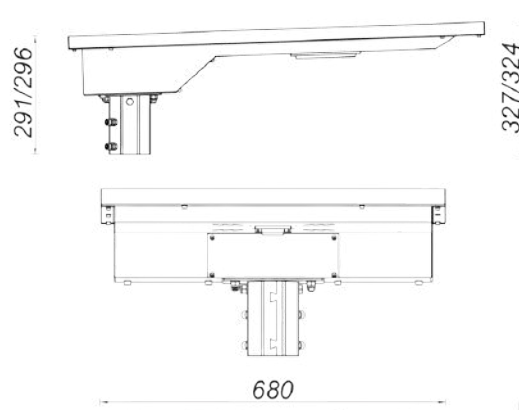
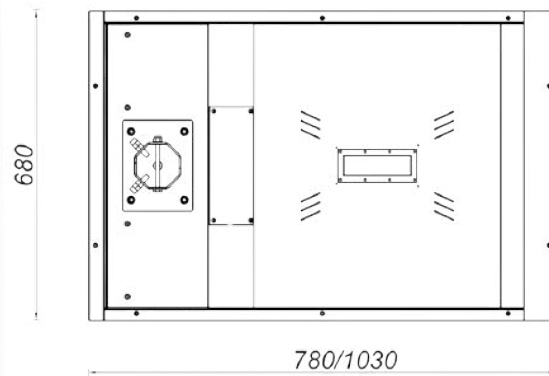

DATA SHEET



# phLUMINAELP2S\_FV

phLuminaELP2S\_FV is a solar-powered lighting solution derived from the phLuminaELP2S model, retaining all its key features. Designed with a die-cast aluminum body, phLuminaELP2S\_FV ensures exceptional durability, optimized for the integration of photovoltaic panels and operation at various current voltages suitable for solar power supply.

Like its reference model, phLuminaELP2S\_FV features impact-resistant tempered glass, along with stainless steel screws. This solar lamp utilizes cutting-edge lighting technology to provide efficient and uniform brightness, effectively reducing light pollution.

Designed for streets, parking lots, parks, and similar environments, phLuminaELP2S\_FV combines longevity and sophistication, reflecting the excellence of Italian craftsmanship. Offering a reliable, efficient, and durable lighting solution, it contributes to enhancing the safety and aesthetics of public spaces with the benefits of green energy, offering long-term savings.

## KEY FEATURES

- Power range: 17W to 95W
- Operating voltages: 36-48-60-72 Vdc
- Luminous efficiency: Up to 159 lm/W
- LED lifetime >100,000 hours
- Smart City compatible
- Photocell options
- Optional dimming
- Customizable color temperature (k)



MAIN CHARACTERISTICS	
Applications	Roadways, Car parks, Parks and Squares, Pathways and Bike Paths, Railway Platforms, etc.
Material	High-pressure die cast aluminium UNI EN 46100
Color	Anthracite (optional RAL 7037). Epoxy powder coating after phosphating
Product sizes	595 (508) x 236 x 117 (202) mm
Exposed surface	Windage: 0.082 m <sup>2</sup> - 0.17 m <sup>2</sup>
Weight	6.0 Kg
Mounting	Side entry/ Post-top: Ø 60 mm
Tilt Angle	Bracket: 5°, 0°, -5°, -10°, -15°, -20° Post-top: 0°, +5°, +10°, +15°, +20°
Insulation Class	CL III (SELV)
Protection degree	IP 66   IK08   IK09 su richiesta
No. LEDs	4, 8, 12, 16, 20, 24 LED
LED Efficacy	201 lm/W - CRI ≥ 70 - @ 360 mA, T = 25 °C   CRI ≥ 80 su richiesta
Color temperature	3000K - 730/669   4000K - 740/669   5700K - 757/669   Other (K) available upon request
LED lifetime	≥ 100.000hr L90B10 LM 80, TM-21
Optics	PMMA street optics in high-performance optical grade
Operating voltages	36 VDC   48 VDC   60 VDC   72 VDC
Control system (options)	0-100%, 0-10V signal, PWM, DALI, AstroDIM, MainsDIM, Wireless, NEMA, ZHAGA
Programming (options)	On-site driver reprogramming through NFC and related app.
Dimming (options)	Optional module for seasonal, weekly, and daily dimming.
Test	Salt spray test environment (according to ASTM B 117-1997); Neutral salt spray(NSS) test(according to UNI ISO 9227); UV test (according to UV ISO 11507); Humidity test (according to UNI EN ISO 6270-1).
Operating temperature	-40 / +55 °C



# SOLAR POWERED LIGHT

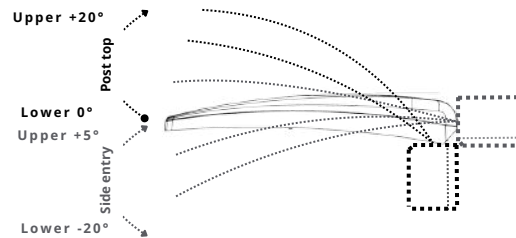
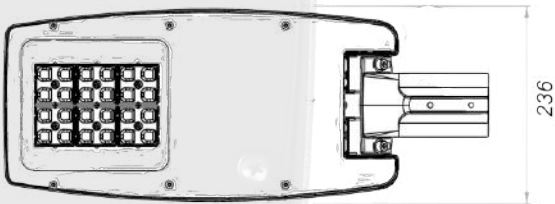
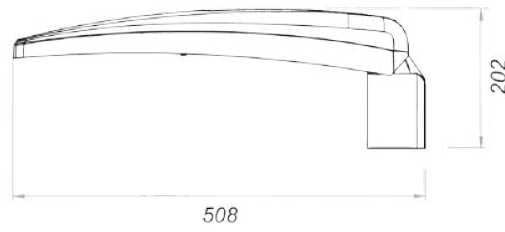
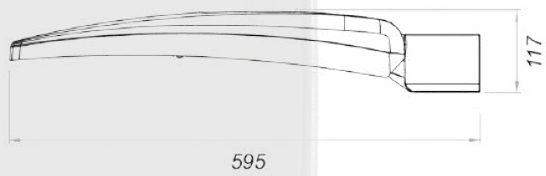

SCAN ME

DATA SHEET



DATA SHEET









# FLOODLIGHTS





# phEvoGEMINI

The phEvoGEMINI projector, entirely conceived and developed in Italy by our company, represents a versatile and reliable lighting solution designed to illuminate large areas effectively and precisely.

Characterized by a robust and resistant design, this projector offers powerful and uniform lighting, ensuring optimal visibility in any context. Thanks to advanced LED technology, it provides efficient and low-energy consumption lighting, while reducing environmental impact without compromising luminous efficiency.

With flexible mounting options and a range of available powers, the phEvoGEMINI projector easily adapts to various needs, from sports fields to industrial spaces, from commercial areas to outdoor events.

Thanks to its reliability and high performance, the phEvoGEMINI projector is the ideal choice for illuminating large spaces, offering an excellent combination of quality, durability, and efficiency.

## KEY FEATURES

- Power range: 71W to 161W
- Luminous efficiency: Up to 153 lm/W
- LED lifetime >100,000 hours
- Smart City compatible
- Photocell options
- Optional dimming
- Customizable color temperature (k)



CARATTERISTICHE PRINCIPALI	
Applications	Area Lighting, Security Lighting, Perimeter Lighting, Retail Parks, Outdoor Retail Sites, etc
Material	High-pressure die cast aluminium UNI EN 46100
Color	Anthracite (optional RAL 7037). Epoxy powder coating after phosphating
Product sizes	315 x 405 x 750 mm
Exposed surface	Windage: 0,13 m <sup>2</sup> - 0,03 m <sup>2</sup>
Weight	7.5 Kg
Mounting	Wall mounting   Post top pole   Suspended with chain
Tilt Angle	Wall mounting: -60° to 60° approx.
Insulation Class	CL I   CL II (on request)
Protection degree	IP 66   IK08   IK09 (on request)
No. LEDs	16, 24, 36 LEDs
LED Efficacy	201 lm/W - CRI ≥ 70 - @ 360 mA, T = 25 °C   CRI≥80 (on request)
Color temperature	3000K - 730/669   4000K - 740/669   5700K - 757/669   Other (K) available upon request
LED lifetime	≥ 100.000hr L90B10 LM 80, TM-21
Optics	Optics in high-performance optical grade PMMA Optics in high-performance optical grade POLYCARBONATE
Operating voltages and frequencies	220-240 V~ 50/60 Hz
Power factor	Cosφ ≥ 0.98 (at full load)
Surge protection (DM/CM)	6/10 kV   SPD (optional) 8kV / 10kV   SPD (optional) with higher capacity
Control system (options)	0-100%, 0-10V signal, PWM, DALI, AstroDIM, MainsDIM, Wireless, NEMA, ZHAGA
Programming (options)	On-site driver reprogramming through NFC and related app.
Dimming (options)	Optional module for seasonal, weekly, and daily dimming.
Test	Salt spray test environment (according to ASTM 117-1997); Neutral salt spray test (according to UNI ISO 9227);
Operating temperature	-40 / +55 °C

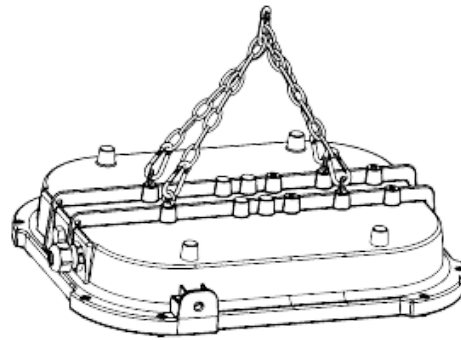
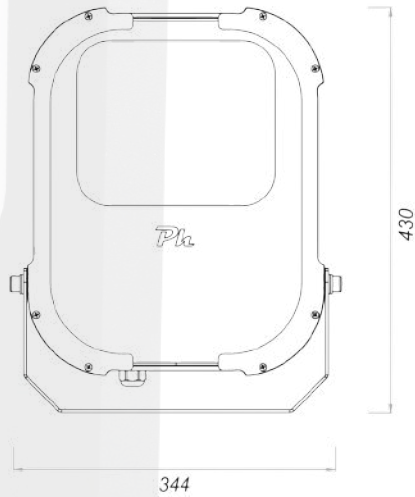

Suspended with chain



DATA SHEET



# phEvoSTADIO

The phEvoStadio is a floodlight designed for large areas such as stadiums, ports, airports, and more. Entirely conceived and developed in Italy by our company, the phEvoStadio floodlight is a versatile and reliable lighting solution, designed to effectively and precisely illuminate extensive areas.

Characterized by a robust and sturdy design, this floodlight provides powerful and uniform illumination, ensuring optimal visibility in any setting. Equipped with advanced LED technology, the floodlight ensures efficient and low-energy lighting, reducing environmental impact without compromising luminous efficiency.

With flexible mounting options and tower floodlight grouping, along with a range of available power options, the phEvoStadio floodlight easily adapts to various needs.

Thanks to its reliability and high performance, the phEvoStadio floodlight is the ideal choice for illuminating large spaces, offering an excellent combination of quality, durability, and efficiency.

## KEY FEATURES

- Power range: 38W to 1366W
- Luminous efficiency: Up to 141 lm/W
- LED lifetime >100,000 hours
- Smart City compatible
- Photocell options
- Optional dimming
- Customizable color temperature (k)
- CRI≥80 | CRI≥90 options



MAIN CHARACTERISTICS	
Applications	Sporting venues, High mast, Large areas, Security, Ports and airports, etc
Material	Powder-coated carbon steel body with heat sink in anodised aluminium
Color	Black RAL9005   Gray RAL9007. Powder coating after phosphating.
Product sizes	Refer to the technical datasheet
Exposed surface	Refer to the technical datasheet
Weight	Refer to the technical datasheet
Mounting	High mast / Wall mounting
Tilt Angle	Refer to the technical datasheet
Insulation Class	CL I   CL II (on request)
Protection degree	IP 66   IK07   IK08 (on request)
No. LEDs	from 8 to 288 LEDs
LED Efficacy	201 lm/W - CRI ≥ 70 - @ 360 mA, T = 25 °C   CRI≥80   CRI≥90 on request
Color temperature	3000K - 730/669   4000K - 740/669   5700K - 757/669   Other (K) available upon request
LED lifetime	≥ 100.000hr L90B10 LM 80, TM-21
Optics	Optics in high-performance optical grade PMMA (IP Type) Optics in high-performance optical grade POLYCARBONATE (IP Type) Optics in high-performance optical grade SILICONE (IP Type)
Operating voltages and frequencies	220-240 V~ 50/60 Hz
Power factor	Cosφ ≥ 0.98 (at full load)
Surge protection (DM/CM)	6/10 kV   SPD (optional) 8kV / 10kV   SPD (optional) with higher capacity
Control system (options)	0-100%, 0-10V signal, PWM, DALI, AstroDIM, MainsDIM, Wireless, NEMA, ZHAGA
Programming (options)	On-site driver reprogramming through NFC and related app.
Dimming (options)	Optional module for seasonal, weekly, and daily dimming.
Operating temperature	-40 / +55 °C



# FLOODLIGHTS



*phEvoSTADIO8*



*phEvoSTADIO36*

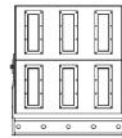

*phEvoSTADIO72*



*phEvoSTADIO12*

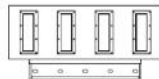

*phEvoSTADIO48*

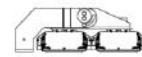
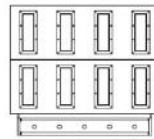

*phEvoSTADIO96*

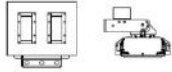

*phEvoSTADIO16*



*phEvoSTADIO24*



*phEvoSTADIO60*

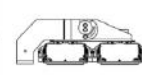
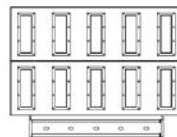

*phEvoSTADIO120*

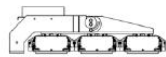

*phEvoSTADIO180*

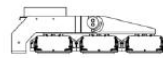
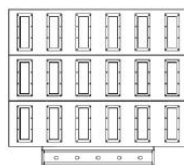

*phEvoSTADIO216*

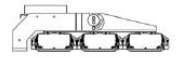
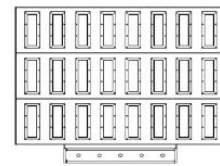

*phEvoSTADIO288*



DATA SHEET



DATA SHEET



# phEvoSTADIOITA

phEvoStadiolTA is a customizable lighting solution that offers high-quality performance. Developed by Phaenomena, this projector is designed to fit artistic or decorative contexts, standing out for its versatility and customization capabilities.

phEvoStadiolTA is a cutting-edge projector that exceeds expectations, allowing lighting customization through RGB or RGBW technology. This option enables the creation of unique lighting scenarios, adjusting the hue and intensity of light according to specific needs. Thanks to Phaenomena's advanced system, the phEvoStadiolTA projector is perfectly suited for artistic lighting, highlighting monuments or creating evocative atmospheres.

Whether it's enhancing artworks, monuments, or artistic events, the phEvoStadiolTA projector offers high-quality customized lighting, contributing to the creation of engaging and immersive atmospheres.

Experience the luminous versatility of the phEvoStadiolTA projector, where performance and customization merge for a unique visual experience.

## KEY FEATURES

- Power range: 39W to 89W
- Luminous efficiency: Up to 117 lm/W
- LED lifetime >100,000 hours
- Smart City compatible
- Photocell options
- Optional dimming
- RGB | RGBW



MAIN CHARACTERISTICS	
Applications	Artistic contexts, Decorative environment
Material	Struttura in acciaio di carbonio con dissipatore in alluminio anodizzato
Color	Black RAL9005   Gray RAL9007. Powder coating after phosphating
Product sizes	Refer to the technical datasheet
Exposed surface	Refer to the technical datasheet
Weight	Refer to the technical datasheet
Mounting	High mast   Wall mounting   Floor mounting
Tilt Angle	Refer to the technical datasheet
Insulation Class	CL I   CL II (on request)
Protection degree	IP 66   IK07   IK08 (on request)
No. LEDs	from 12 to 120 LEDs
LED Efficacy	130 lm/W - @ 350 mA, T = 25 °C
Color temperature	RGB   RGBW
LED lifetime	≥ 100.000hr L90B10 LM 80, TM-21
Optics	Optics in high-performance optical grade PMMA (IP Type) Optics in high-performance optical grade POLYCARBONATE (IP Type) Optics in high-performance optical grade SILICONE (IP Type)
Operating voltages and frequencies	220-240 V~ 50/60 Hz
Power factor	Cosφ ≥ 0.98 (at full load)
Surge protection (DM/CM)	6/10 kV   SPD (optional) 8kV / 10kV   SPD (optional) with higher capacity
Control system (options)	0-100%, 0-10V signal, PWM, DALI, AstroDIM, MainsDIM, Wireless, NEMA, ZHAGA
Programming (options)	On-site driver reprogramming through NFC and related app.
Dimming (options)	Optional module for seasonal, weekly, and daily dimming.
Operating temperature	-40 / +55 °C

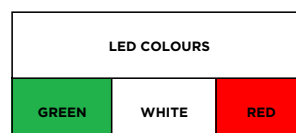



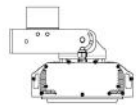
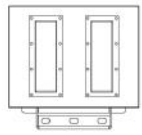

*phEvoSTADIO24*

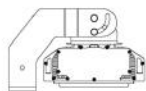
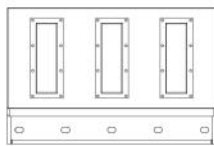

*phEvoSTADIO36*

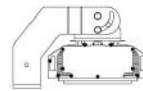
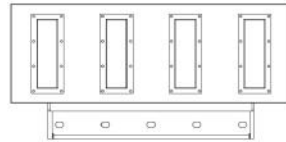

*phEvoSTADIO48*



DATA SHEET



DATA SHEET









# TUNNEL

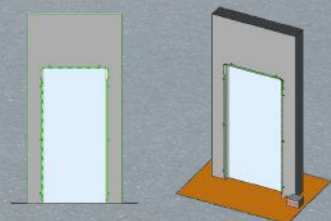
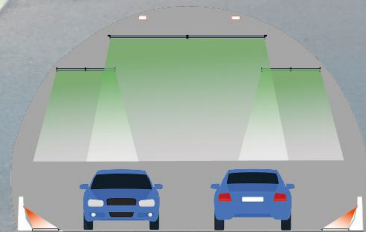

# phEvoTUNNEL

phEvoTUNNEL is a robust and versatile lighting solution designed for critical environments such as tunnels, subways, industrial applications, railways, and more. Assembled with high-quality materials, phEvoTUNNEL is engineered to deliver reliable performance in the most demanding conditions. This product is extraordinarily durable, built with anti-corrosion materials, ensuring exceptional longevity even in highly humid and aggressive environments like tunnels and underpasses.

The body and 5mm tempered glass with IK08 impact resistance provide reliable protection against possible impacts, ensuring long-term operational durability.

phEvoTUNNEL offers the option to install remote control systems and light intensity adjustment, allowing flexible control of lighting based on the specific needs of the application. This additional functionality enables optimization and management of energy resources, providing an advanced lighting solution for transportation environments and infrastructures.

With its robustness, durability, and advanced functionality, the phEvoTUNNEL projector is the ideal choice to ensure reliable and efficient lighting in critical environments.

## KEY FEATURES

- Power range: 24W to 318W
- Luminous efficiency: Up to 155 lm/W
- LED lifetime >100,000 hours
- Smart City compatible
- Photocell options
- Optional dimming
- Customizable color temperature (k)



MAIN CHARACTERISTICS	
Applications	Tunnels, Underpasses, Industrial environment, etc
Material	Anodized extruded aluminum body, stainless steel AISI 403 brackets
Color	Anthracite. Powder coating with after phosphating treatment.
Product sizes	Refer to the technical datasheet
Exposed surface	Refer to the technical datasheet
Weight	Refer to the technical datasheet
Mounting	Suspended   Channel system
Security System	Stainless steel safety chain between projector and cable tray
Insulation Class	CL II   CL I (on request)
Protection degree	IP 66   IK 08
No. LEDs	from 12 to 192 LEDs
LED Efficacy	201 lm/W - CRI ≥ 70 - @ 360 mA, T = 25 °C   CRI≥80 (on request)
Color temperature	3000K - 730/669   4000K - 740/669   5700K - 757/669   Other (K) available upon request
LED lifetime	≥ 100.000hr L90B10 LM 80, TM-21
Optics	Optics in high-performance optical grade PMMA Optics in high-performance optical grade POLYCARBONATE
Operating voltages and frequencies	220-240 V~ 50/60 Hz
Power factor	Cosφ ≥ 0.98 (at full load)
Surge protection (DM/CM)	6/10 kV   SPD (optional) 8kV / 10kV   SPD (optional) with higher capacity
Control system (options)	0-100%, 0-10V signal, PWM, DALI, AstroDIM, MainsDIM, Wireless, NEMA, ZHAGA
Programming (options)	On-site driver reprogramming through NFC and related app.
Dimming (options)	Optional module for seasonal, weekly, and daily dimming.
Operating temperature	-40 / +55 °C



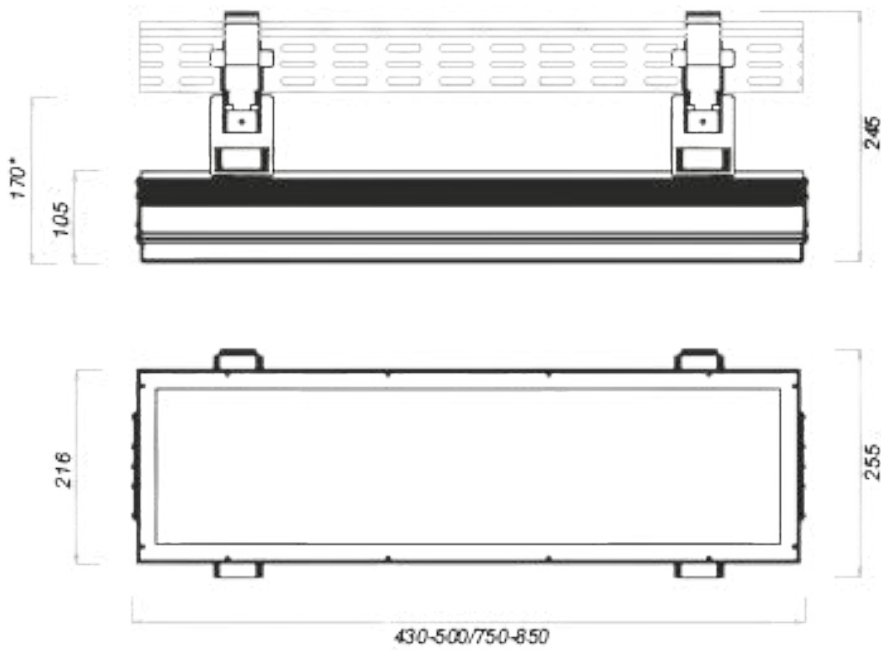

DATA SHEET

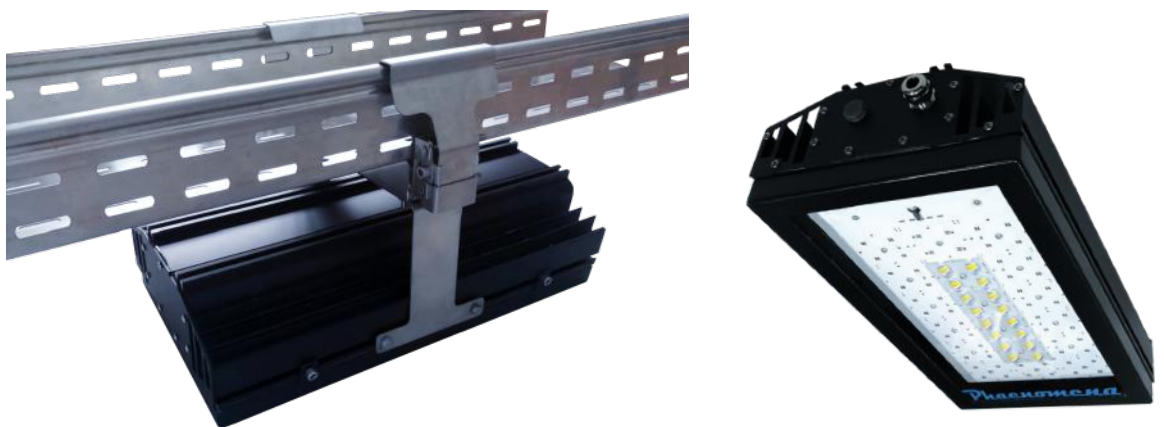

# Pegaso

Pegaso is a versatile lighting solution designed for various applications, including tunnels, metro stations, industrial environments, and railways.

Precision-crafted by Phaenomena, Pegaso offers adaptability and efficiency, making it suitable for diverse lighting needs. Its design and power capabilities make it an ideal choice for spaces where versatility and a compact profile are essential.

Pegaso offers the option to install remote control systems and light intensity adjustment, allowing flexible lighting control based on specific application needs. This additional functionality enables optimization and management of energy resources, providing an advanced lighting solution for transportation environments and infrastructure.

Whether illuminating tunnels, metro stations, or industrial facilities, Pegaso offers reliable and efficient lighting, ensuring high performance and long operational life.

## KEY FEATURES

- Power range: 24W to 53W
- Luminous efficiency: Up to 155 lm/W
- LED lifetime >100,000 hours
- Smart City compatible
- Photocell options
- Optional dimming
- Customizable color temperature (k)



MAIN CHARACTERISTICS	
Applications	Tunnel, Subway, Metro station, industrial environment, etc
Material	Extruded anodized aluminum body / Tempered glass resistant to impacts
Color	Black or RAL on request. Powder coating after phosphating
Product sizes	500mm X 128mm X 90mm
Exposed surface	Windage: 0.064 m <sup>2</sup> - 0.045 m <sup>2</sup>
Weight	max 4,5 Kg
Mounting	Refer to the technical data sheet
Insulation Class	CL II   CL I on request
Protection degree	IP 66   IK07   IK08 on request
No. LEDs	from 6 to 24 LEDs
LED Efficacy	201 lm/W - CRI ≥ 70 - @ 360 mA, T = 25 °C   CRI≥80 on request
Color temperature	3000K - 730/669   4000K - 740/669   5700K - 757/669   Altre (K) disponibili su richiesta
LED lifetime	≥ 100.000hr L90B10 LM 80, TM-21
Optics	Optics in high-performance optical grade PMMA Optics in high-performance optical grade POLYCARBONATE Optics in high-performance optical grade SILICONE High-performance optical REFLECTION street optics
Operating voltages and frequencies	220-240 V~ 50/60 Hz
Power factor	Cosφ ≥ 0.98 (at full load)
Surge protection (DM/CM)	6/10 kV   SPD (optional) 8kV / 10kV   SPD (optional) with higher capacity
Control system (options)	0-100%, 0-10V signal, PWM, DALI, AstroDIM, MainsDIM, Wireless, NEMA, ZHAGA
Programming (options)	On-site driver reprogramming through NFC and related app.
Dimming (options)	Optional module for seasonal, weekly, and daily dimming.
Operating temperature	-40 / +55 °C



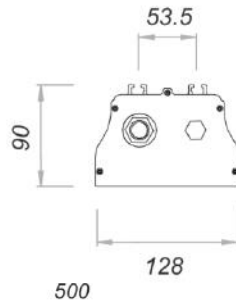

DATA SHEET

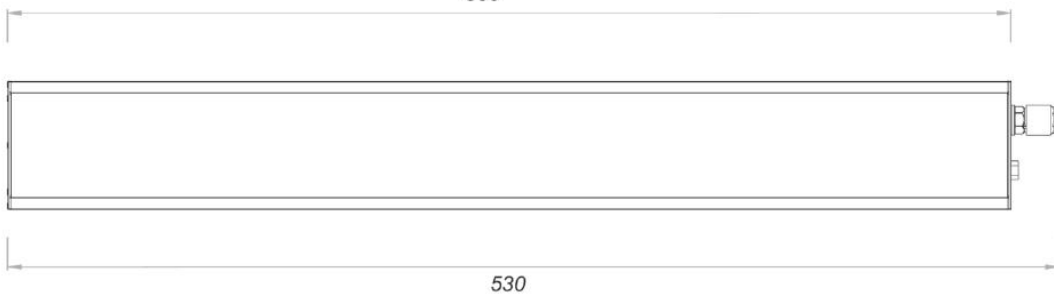

# CarLed

Introducing CarLed, an innovation in road safety. This product is specifically designed for safety lighting and signaling in tunnels, underpasses, roads, subways, railways, and similar applications.

Crafted with a corrosion-resistant anodized aluminum profile, the protective screen is made of extruded self-extinguishing polycarbonate with an extremely high degree of resistance and protection against high temperatures, ensuring durability and reliability in demanding environments.

Compliant with the most important reference standards for electrical installations in tunnels and for additional thermal protections.

One of CarLed's strengths is its seamless installation over considerable distances, providing extended coverage for enhanced safety and visibility.

This innovative lighting solution combines versatility with high-quality construction, making it an ideal choice for various road and transportation scenarios.

Experience the future of road safety with CarLed, where hi-tech and robust materials come together to illuminate and protect various infrastructure environments.

## KEY FEATURES

- Power: MAX 1.8W/meter  
MAX 2.2W/meter
- Color Temperature options
- Various mounting options
- Continuous installation over large areas
- Fire rated material
- CEI 64-20: Electrical installations in road tunnels
- CEI 34-193: Additional thermal performance



MAIN CHARACTERISTICS		
Applications	Security or emergency light for roads tunnels, subways, etc.	
Material	Anodized aluminum body	
Compliant with regulations	CEI 64-20: Electrical systems in road tunnels CEI 34-193: Tunnel lighting with additional thermal performance (For all standards, please refer to the technical data sheet)	
Protective screen	Extruded self-extinguishing polycarbonate	
Color	Black or RAL upon request	
Product sizes	3000mm (o custom) x 80mm x 25mm - Recessed mounting 3000mm (o custom) x 97mm x 27mm - Wall mounting 1 3000mm (o custom) x 170mm x 32mm - Wall mounting 2	
Weight	max 4 Kg	
Mounting	Recessed mounting   Wall mounting	
Insulation Class	CL III (SELV)	
Protection degree	IP 65   IK07	
No. LEDs	10 LEDs at 6V	14 LEDs at 3V
LED Efficacy	59 lm/W - @ 150 mA, T = 25 °C	74lm/W - @ 150 mA, T = 25 °C
Color temperature	Yellow/Amber	White (4000K)
LED lifetime	≥ 100.000hr L90B10 LM 80, TM-21	≥ 100.000hr L90B10 LM 80, TM-21
Operating voltages	48 VDC	48 VDC
Power range	MAX 1.8W/meter	MAX 2.2W/meter
Driver	Installed in the electrical panel	
Power factor driver	Cosφ ≥ 0.98 (at full load)	
Control system (options)	0-100%, 0-10V signal, PWM, DALI, AstroDIM, MainsDIM, Wireless, NEMA, ZHAGA	
Programming (options)	On-site driver reprogramming through NFC and related app.	
Operating temperature	-40 / +100 °C	



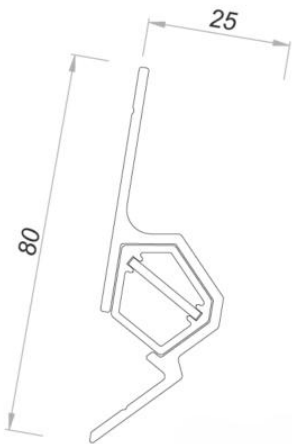

Recessed mounting

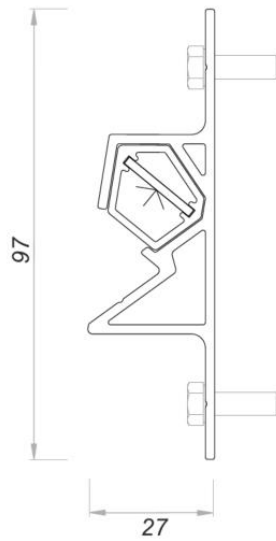

Wall mounting 1

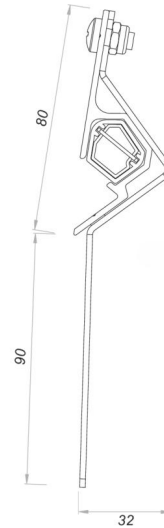

Wall mounting 2



DATA SHEET

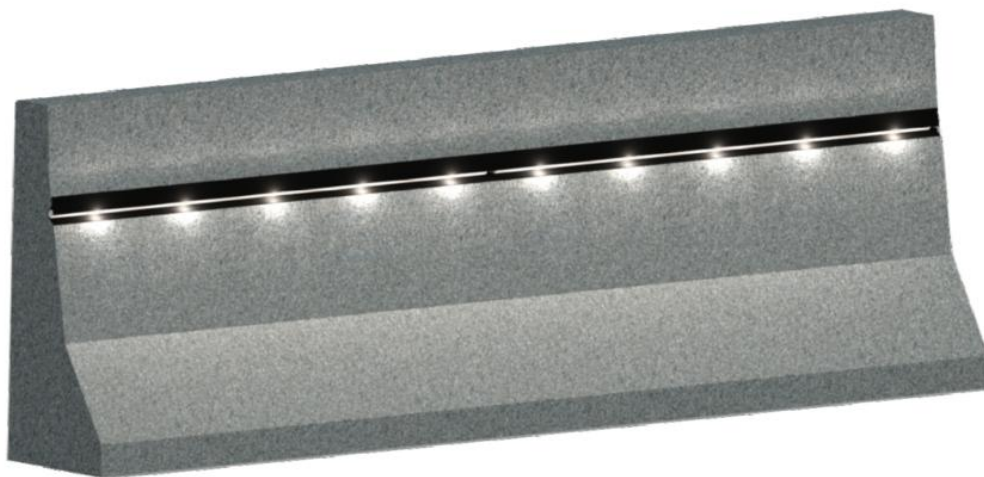

# BladeWaterLed

LED lighting device for safety and signaling illumination for water blades in environments such as tunnels, underpasses, roads, subways, railways, this device offers a comprehensive lighting solution in critical environments.

The LED lighting device is designed to ensure reliable and long-lasting illumination in a wide range of environments and scenarios. Thanks to its profile in extruded anodized aluminum, it is able to withstand corrosion even in adverse environmental conditions, ensuring optimal performance over time. The two-component resin that protects the LED module not only serves as an optical screen to ensure uniform light distribution but also provides robust protection against weathering and impacts, ensuring long-term operational durability.

With an IP66 protection rating, this device is able to withstand the ingress of dust and water, ensuring reliable operation even in the most challenging conditions.

## KEY FEATURES

- Power range: MAX 6W/meter
- Luminous efficiency up to 61 lm/W
- Critical environments and safety
- Fire rated materials



MAIN CHARACTERISTICS	
Applications	Emergency lighting or signaling for tunnel water blade in case of emergency
Material	Body in extruded anodized aluminum.
Protective screen	Bicomponent resin sealing.
Color	Grey. Epoxy powder coating with prior phosphating treatment and anticorrosion technology.
Product sizes	1800mm x 32mm x 17mm 3000mm x 32mm x 17mm
Weight	Max 1.5 Kg (1800mm) Max 3.0 Kg (3000mm)
Mounting	Suspension   Ceiling   Wall
Insulation Class	CL III (SELV)
Protection degree	IP 66
No. LEDs	144 LED dim. 1800mm 240 LED dim. 3000mm
LED Efficacy	61 lm/W - @ 150 mA, T = 25 °C
Color temperature	Emergency colors
LED lifetime	≥ 100.000hr L90B10 LM 80, TM-21
Power range	MAX 6W /meter
Operating voltages	MAX 48 VDC
Driver	Installed in the electrical panel
Power factor driver	Cosφ ≥ 0.9 (at full load)
Operating temperature	-40 / +100 °C



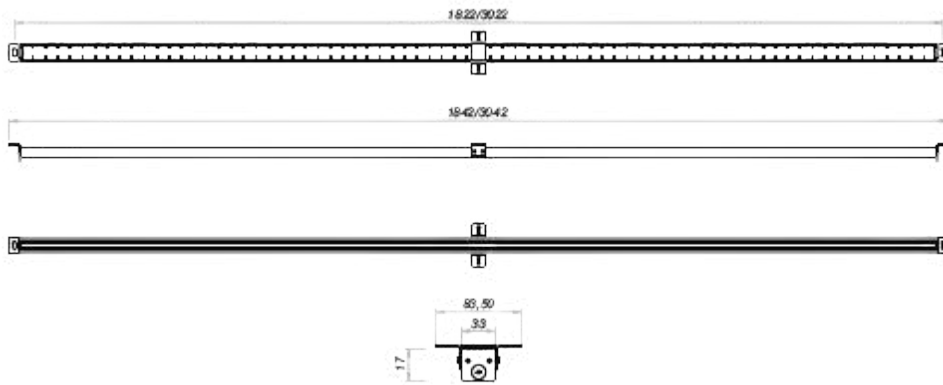

DATA SHEET

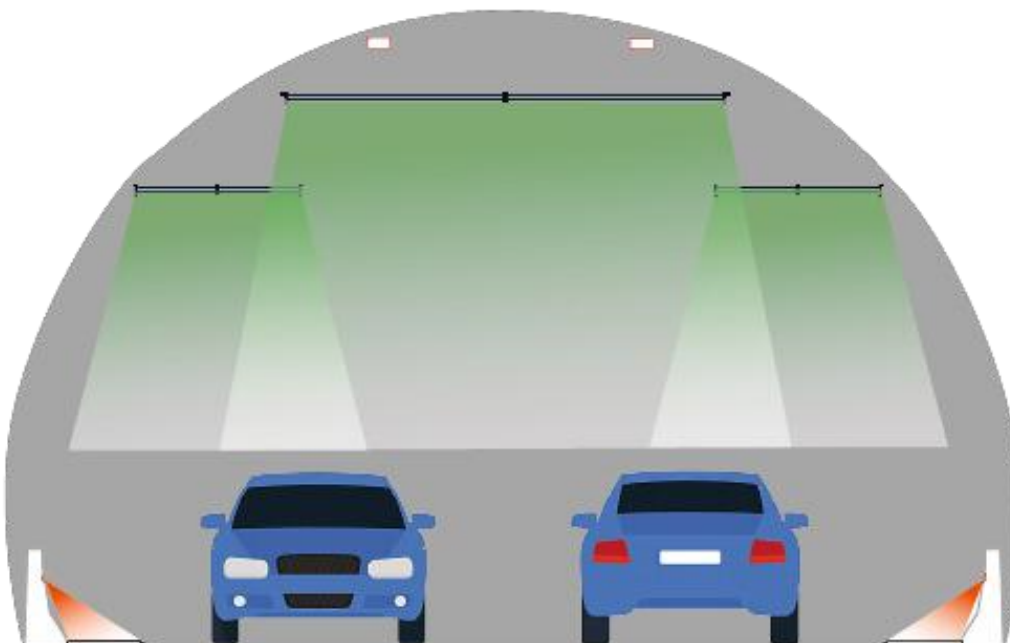

# ByPassLed

The ByPassLed devices are specifically designed for safety and emergency exit signaling purposes in various environments such as tunnels, underpasses, industrial areas, roads, subways, and railways.

The complete system consists of two lateral light bars and one top bar installed on the fire door.

These devices feature a sturdy profile made of extruded polycarbonate and are housed inside a corrosion-resistant stainless steel case for wall mounting, closed on both sides with caps for added protection.

The LED modules are protected by a self-extinguishing polycarbonate screen capable of withstanding fires for long-lasting durability and serve as both an optical screen and protection.

With an IP65 protection rating and Class III insulation, these devices ensure durability and resistance to adverse environmental conditions.

The power supply operates at a continuous voltage of 24/48VDC and is mounted in the zone panel, ensuring easy access and maintenance.

## KEY FEATURES

- Power: MAX 5W/meter
- Luminous efficiency: Up to 61 lm/W
- Critical and safety environments
- Customizable profile color
- Fire-rated material



MAIN CHARACTERISTICS	
Applications	Emergency lighting or signaling for tunnel bypass doors
Material	Stainless steel body.
Protective screen	Extruded self-extinguishing polycarbonate
Color	Customizable. Epoxy powder coating with anti-corrosion technology
Product sizes	1000mm x 24mm x 20mm 1950mm x 24mm x 20mm
Weight	MAX 1.0 Kg (1000mm) MAX 2.0 Kg (1950mm)
Mounting	Ceiling   Wall
Insulation Class	CL III (SELV)
Protection degree	IP 65
No. LEDs	16 LEDs size 1000mm 32 LEDs size 3000mm
LED Efficacy	61 lm/W - @ 150 mA, T = 25 °C
Color temperature	Green
LED lifetime	≥ 100.000hr L90B10 LM 80, TM-21
Operating voltages	MAX 48 VDC
Power range	MAX 5W/meter
Driver	Installed in the electrical panel
Power factor driver	Cosφ ≥ 0.9 (at full load)
Operating temperature	-40 / +100 °C





DATA SHEET

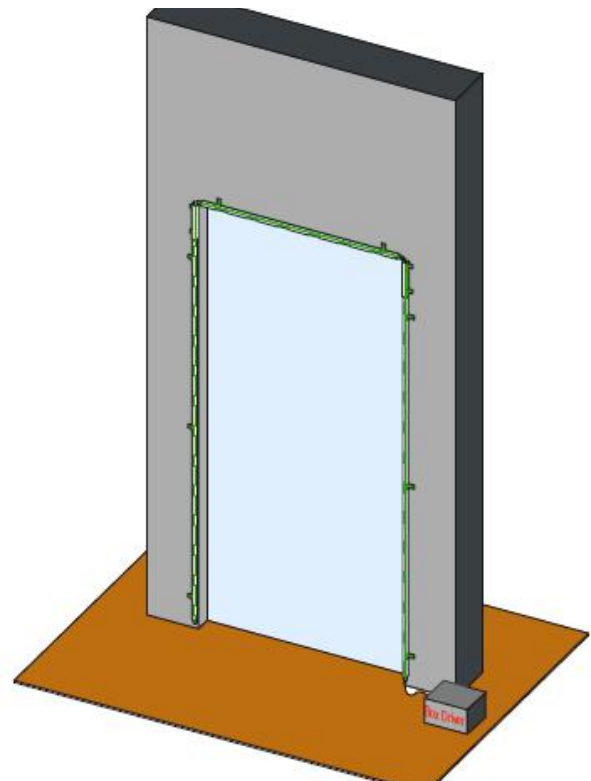
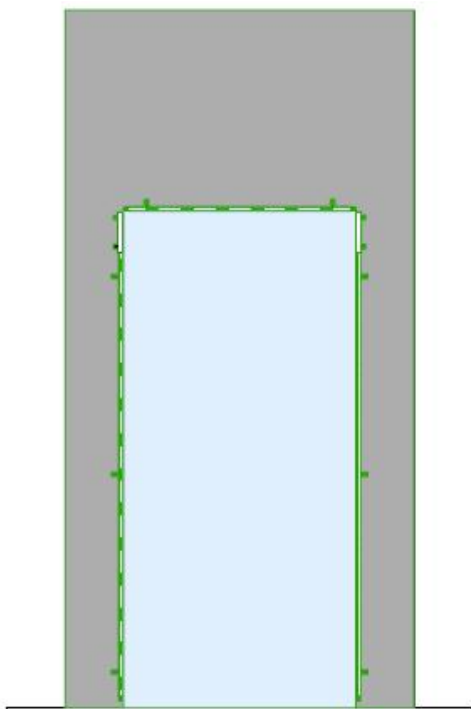





# INDOOR | INDUSTRIAL



# phLUMINAOFFICE

phLuminaOFFICE is the interior lighting solution designed for offices, schools, commercial premises, and similar indoor environments.

Characterized by a structure made of extruded and press-bent aluminum sheet, coated with epoxy powder paint, phLuminaOFFICE offers a sophisticated and functional lighting solution for indoor spaces.

Available in recessed and ceiling-mounted versions, it perfectly adapts to various usage needs. The rotosymmetric optics made of high-performance optical PMMA with low luminance are specifically designed for work environments, creating a comfortable visual atmosphere and reducing eye fatigue.

The adjustable luminous flux allows for personalized control of the lighting, with the possibility to adapt it to the specific requirements of the workspace. Thanks to the long-lasting LED technology, phLuminaOFFICE minimizes the need for maintenance and replacement, ensuring significant long-term cost savings.

phLuminaOFFICE creates a well-lit, efficient, and low-impact environment to enhance well-being and productivity.

## KEY FEATURES

- Power range: 9.5W to 36W
- Luminous efficiency: Up to 155 lm/W
- LED lifetime >100,000 hours
- Low-glare optics
- Customizable color temperature (k)
- CRI≥80 | CRI≥90 option



MAIN CHARACTERISTICS	
Applications	Indoor lighting, Schools, Offices, Clinics, Workspaces, etc.
Material	Pressed and bent sheet aluminum body
Color	White   Gray. Powder epoxy coating after phosphating
Product sizes	595 x 595 x 37 mm - Recessed version 600 x 600 x 50mm - Surface-mounted version
Weight	3.5 Kg (Recessed version) 4.0 Kg (Surface-mounted version)
Mounting	Recessed   Surface-mounted
Insulation Class	CL II   CL I on request
Protection degree	IP 20
No. LEDs	96 LEDs
LED Efficacy	201 lm/W - CRI ≥ 70 - @ 360 mA, T = 25 °C   CRI≥80   CRI≥90 (on request)
Color temperature	3000K - 730/669   4000K - 740/669   5700K - 757/669   Other (K) available upon request
LED lifetime	≥ 60.000hr L90B10 LM 80, TM-21
Optics	Rotosymmetric optics in PMMA with high optical efficiency and low luminance
Operating voltages and frequencies	220-240 V~ 50/60 Hz
Power factor	Cosφ ≥ 0.98 (at full load)
Control system (options)	Optional control system
Programming (options)	On-site driver reprogramming through NFC and related app.
Dimming (options)	Optional module for seasonal, weekly, and daily dimming.
Operating temperature	-40 / +55 °C



# INDOOR/INDUSTRIAL

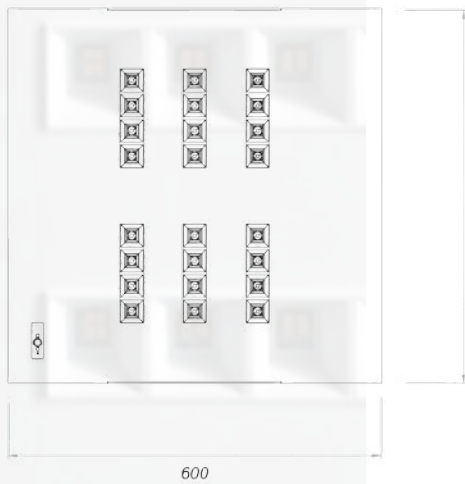

DATA SHEET



DATA SHEET



# phEvoINDUSTRIA

phEvoINDUSTRIA, a robust and versatile lighting solution designed for large indoor spaces such as factories, industries, warehouses, transit areas, and similar environments.

Assembled with high-quality materials, phEvoINDUSTRIA is designed to deliver reliable performance in industrial environments and critical conditions. This product is exceptionally durable, built with materials resistant to mechanical impacts and corrosion to ensure exceptional longevity, even in extreme environments such as factories and warehouses. The 5mm tempered glass with IK08 impact resistance provides reliable protection against potential impacts, ensuring prolonged operational life.

phEvoINDUSTRIA offers the option to install remote control systems and light intensity adjustment, allowing flexible control tailored to specific needs. This additional feature optimizes energy efficiency and resource management, offering an advanced lighting solution for large-scale indoor environments.

With its strength, durability, and advanced functionality, phEvoINDUSTRIA is the optimal choice to ensure reliable and efficient lighting in large and demanding industrial spaces.

## KEY FEATURES

- Power range: 27W to 318W
- Luminous efficiency: Up to 155 lm/W
- LED lifetime >100,000 hours
- Low-glare optics
- Customizable color temperature (k)
- CRI≥80 | CRI≥90 option



MAIN CHARACTERISTICS	
Applications	Industrial and Factories environments, Warehouses, Transit Areas
Material	Body in anodized extruded aluminum, brackets in stainless steel AISI 403
Color	Black (RAL 9005)   Grey (RAL 9007). Polyester powder coating with prior phosphating
Product sizes	Available in various models. See technical datasheet for details
Exposed surface	Available in various models. See technical datasheet for details
Weight	Available in various models. See technical datasheet for details
Mounting	Suspension   Wall   Pole
Insulation Class	CL II   CL I on request
Protection degree	IP 66   IK 08
No. LEDs	from 12 to 144 LEDs
LED Efficacy	201 lm/W - CRI ≥ 70 - @ 360 mA, T = 25 °C   CRI≥80   CRI≥90 (on request)
Color temperature	3000K - 730/669   4000K - 740/669   5700K - 757/669   Other (K) available upon request
LED lifetime	≥ 100.000hr L90B10 LM 80, TM-21
Optics	Optics in high-performance optical grade PMMA Optics in high-performance optical grade POLYCARBONATE Optics in high-performance optical grade REFLECTION
Operating voltages and frequencies	220-240 V~ 50/60 Hz
Power factor	Cosφ ≥ 0.98 (at full load)
Control system (options)	0-100%, 0-10V signal, PWM, DALI, AstroDIM, MainsDIM, Wireless, NEMA, ZHAGA
Programming (options)	On-site driver reprogramming through NFC and related app.
Dimming (options)	Optional module for seasonal, weekly, and daily dimming.
Operating temperature	-40 / +55 °C



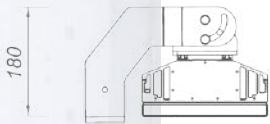

Attacco Palo/Parete

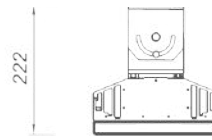

Attacco Soffitto



DATA SHEET

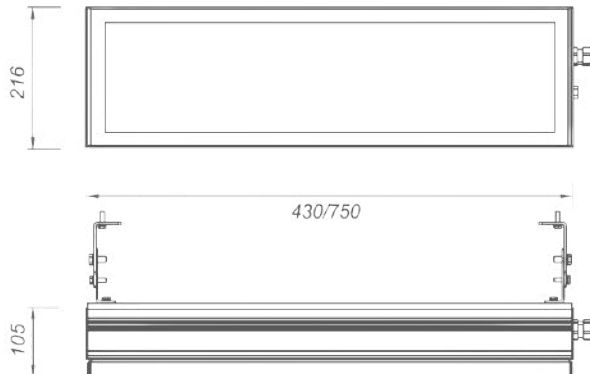
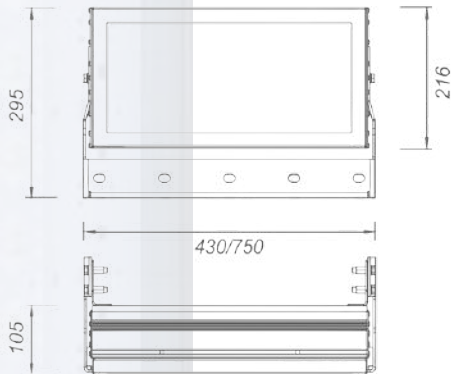

DATA SHEET





**Phaciotmeia<sup>®</sup>**  
**LIGHTING**



**Get ready for the latest in lighting technology!**

**Innovative design and functionality are coming  
your way with our new lighting devices!**



**COMING SOON**

Ph

To stay informed about our latest developments, upcoming products, and to explore our complete product range, we encourage you to visit our website and follow our social media.



[www.phaenomena.it](http://www.phaenomena.it)



Phaenomena S.p.A.



[phaenomenaspa](https://www.instagram.com/phaenomenaspa)

SCAN  
ME FOR  
MORE  
INFO



[CLICK HERE](#)





## **DISCLOSURE**

In order to encourage constant updating of products, Phaenomena S.p.A. reserves the right to make changes or updates without any prior notice.

The product features listed are subject to changes and will be confirmed at the time of quotations or orders.

Graphics, content, and layout of all pages are the exclusive property of the company and their respective authors.

Reproduction, even in part and by any means, of the texts or material is prohibited without prior written permission.

All registered trademarks shown on these pages are the property of their respective owners. These trademarks are mentioned for informational purposes only, and the company has no rights over them.



Phaenomena S.p.A.  
Via XX Settembre, snc  
84033 Montesano S/M (SA)  
Tel: +39 0975 863406  
info@phaenomena.it  
[www.phaenomena.it](http://www.phaenomena.it)

SCAN  
ME FOR  
MORE  
INFO

